

**DEVELOPMENT OF DC SMART PLUG CONTROL SYSTEM**

การพัฒนาระบบควบคุมปลั๊กอัจฉริยะสำหรับไฟฟ้ากระแสตรง

The seal of Chiang Mai Rajabhat University is a large, circular emblem in the background. It features a central tiered stupa with a flame-like top, surrounded by a sunburst pattern. Below the stupa is a circular emblem containing a caduceus (a staff with two snakes). The entire seal is enclosed in a double-lined border. The Thai text 'มหาวิทยาลัยราชภัฏเชียงใหม่' is written along the top inner edge, and 'CHIANG MAI RAJABHAT UNIVERSITY' is written along the bottom inner edge.

**NARAKORN SONGKITIROTE**

**A THESIS SUBMITTED IN PARTIAL FULFILLMENT  
OF THE REQUIREMENTS FOR  
THE MASTER OF SCIENCE PROGRAM IN  
COMMUNITY ENERGY AND ENVIRONMENT  
GRADUATE SCHOOL  
CHIANG MAI RAJABHAT UNIVERSITY**

**2019**

**The Title** Development of DC Smart Plug Control System  
**The Author** Narakorn Songkittirote  
**Program** Community Energy and Environment  
**Thesis Advisors**  
**Advisor** Dr. Hathaithip Sintuya  
**Co-Advisor** Dr. Worajit Setthapun

---

**Thesis Defense Committee**

.....Chairman  
(Dr. Sayan Unankard)

.....Member  
(Dr. Hathaithip Sintuya)

.....Member  
(Dr. Worajit Setthapun)

Graduate School at Chiang Mai Rajabhat University approved this thesis as partial fulfillment of requirements for the Master of Science Program in Community Energy and Environment

.....Dean of Graduate School  
(Assistant Professor Dr. Kamolnut Pholwan)

Date.....

Copyright of Graduate School, Chiang Mai Rajabhat University

**The Title** : Development of DC Smart Plug Control System

**The Author** : Narakorn Songkittirote

**Program** : Community Energy and Environment

**Thesis Advisors** : Dr. Hathaithip Sintuya Chairman

: Dr. Worajit Setthapun Member

### ABSTRACT

Smart plug system is an important device for the energy management in smart homes. With an increase of PV rooftop installation in the residential sector, the development of DC smart plug is necessary. The benefit of DC smart plug is that it can directly control and manage the Direct Current produced from the PV systems. In this work, the DC smart plug prototype and control system was developed with a focus on electronics, data transmission protocol, cloud system and web application. The DC smart plug was able to control DC appliances, measure power consumption with a compact sensor, transmit data between sensor networks, and display real-time data. The results from the DC smart plug evaluation revealed that the plug is efficient, affordable and safe. Smart plugs can display an energy consumption rate of the electrical appliances which could create awareness to the users with regard to their energy consumption behavior. The users can access the previous and real-time electricity consumption data.

**Keywords:** DC Power, Electrical Control System, Smart Plug, Power Management

### III

หัวข้อวิทยานิพนธ์ : การพัฒนาระบบควบคุมปลั๊กอัจฉริยะสำหรับไฟฟ้ากระแสตรง

ผู้วิจัย : นรากรณ์ สังกิตติโรจน์

สาขาวิชา : พลังงานและสิ่งแวดล้อมชุมชน

อาจารย์ที่ปรึกษาวิทยานิพนธ์

: ดร.หทัยทิพย์ สีนรุธยา

อาจารย์ที่ปรึกษาวิทยานิพนธ์หลัก

: ดร.วรจิตต์ เศรษฐพรพงศ์

อาจารย์ที่ปรึกษาวิทยานิพนธ์ร่วม

#### บทคัดย่อ

แนวคิดบ้านอัจฉริยะสำหรับไฟฟ้ากระแสตรง เป็นแนวคิดที่นำความรู้ทางด้านพลังงานทดแทน และการจัดการพลังงานเข้ามาประยุกต์ใช้งานเพื่อช่วยให้การใช้พลังงานไฟฟ้ามีประสิทธิภาพสูงสุด บ้านอัจฉริยะสำหรับไฟฟ้ากระแสตรงจะสามารถนำพลังงานที่ผลิตได้เองจากระบบโซลาร์รูฟมาใช้ได้โดยตรง และระบบปลั๊กอัจฉริยะจะสามารถควบคุมเครื่องใช้ไฟฟ้าภายในบ้านให้ เปิด/ปิด การทำงานตามคำสั่งของผู้ใช้งานได้ ดังนั้นแนวคิดบ้านอัจฉริยะสำหรับไฟฟ้ากระแสตรงจึงเป็นแนวคิดที่สำคัญต่อการอนุรักษ์พลังงาน ในงานวิจัยนี้ได้พัฒนาต้นแบบระบบควบคุมปลั๊กอัจฉริยะสำหรับไฟฟ้ากระแสตรง โดยเน้นที่อุปกรณ์อิเล็กทรอนิกส์ โปรโตคอลการส่งข้อมูล ระบบคลาวด์ และเว็บแอปพลิเคชัน เพื่อให้ปลั๊กอัจฉริยะสามารถควบคุมเครื่องใช้ไฟฟ้า และวัดการใช้พลังงานด้วยเซ็นเซอร์ขนาดเล็ก พร้อมกับส่งข้อมูล และแสดงข้อมูลแบบเรียลไทม์ผ่านระบบออนไลน์ จากผลการดำเนินการพัฒนาระบบปลั๊กอัจฉริยะสำหรับไฟฟ้ากระแสตรง พบว่าระบบปลั๊กมีประสิทธิภาพ มีราคาที่ถูก และปลอดภัย สามารถนำไปใช้งานได้จริง ระบบออนไลน์ของปลั๊กอัจฉริยะสามารถแสดงผลอัตราการใช้พลังงานของเครื่องใช้ไฟฟ้า ผู้ใช้สามารถเข้าถึงข้อมูลการใช้ไฟฟ้าย้อนหลัง และดูข้อมูลปัจจุบันแบบเรียลไทม์ ซึ่งจะช่วยให้ผู้ใช้งานเกิดความตระหนักต่อการใช้พลังงาน

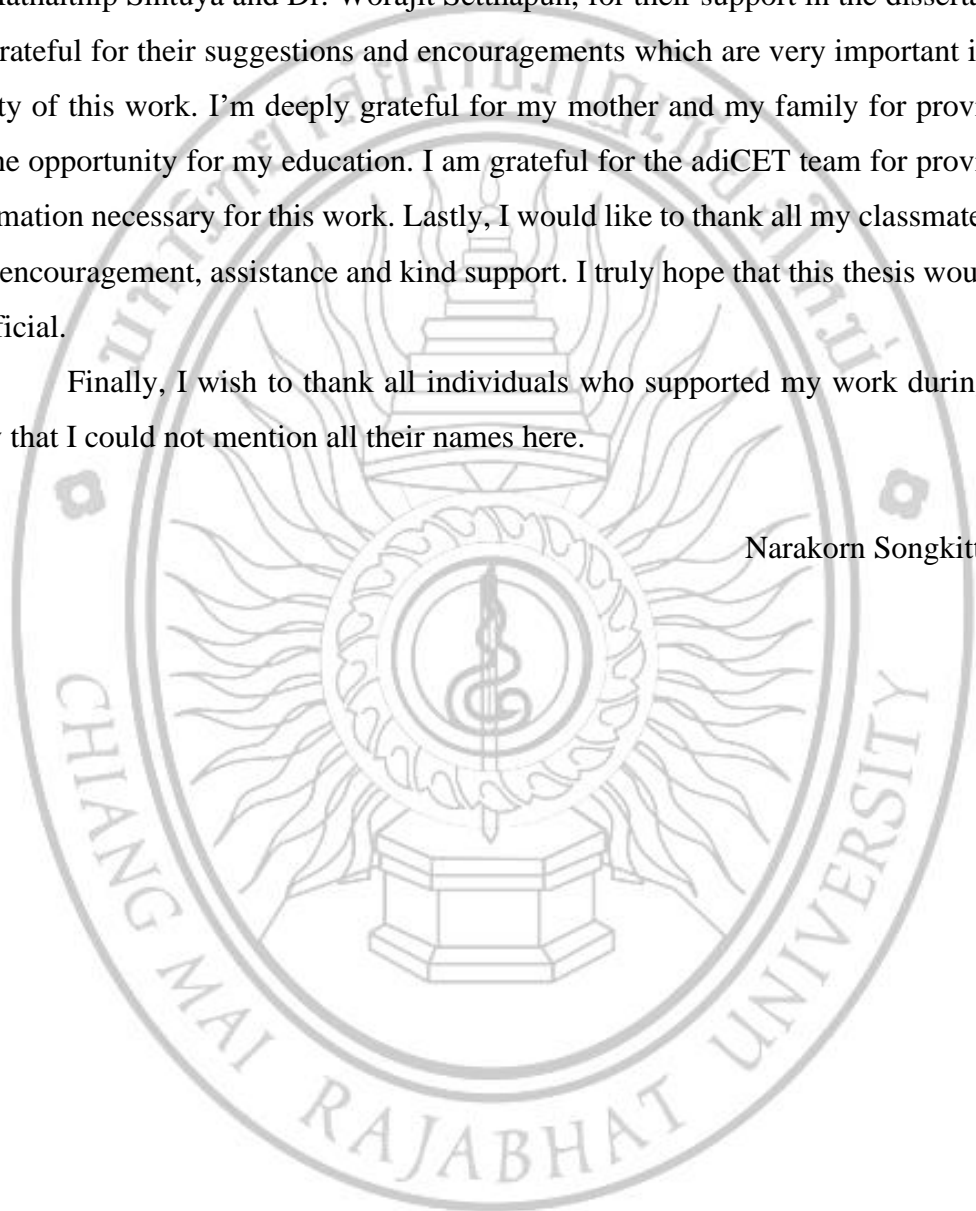
คำสำคัญ: ไฟฟ้ากระแสตรง, ระบบควบคุมเครื่องใช้ไฟฟ้า, ปลั๊กอัจฉริยะ, การจัดการพลังงาน

## ACKNOWLEDGEMENTS

I would like to thank and offer my sincere gratitude to my advisor, Dr. Hathaithip Sintuya and Dr. Worajit Setthapun, for their support in the dissertation. I'm grateful for their suggestions and encouragements which are very important in the quality of this work. I'm deeply grateful for my mother and my family for providing me the opportunity for my education. I am grateful for the adiCET team for providing information necessary for this work. Lastly, I would like to thank all my classmates for their encouragement, assistance and kind support. I truly hope that this thesis would be beneficial.

Finally, I wish to thank all individuals who supported my work during the study that I could not mention all their names here.

Narakorn Songkittirote

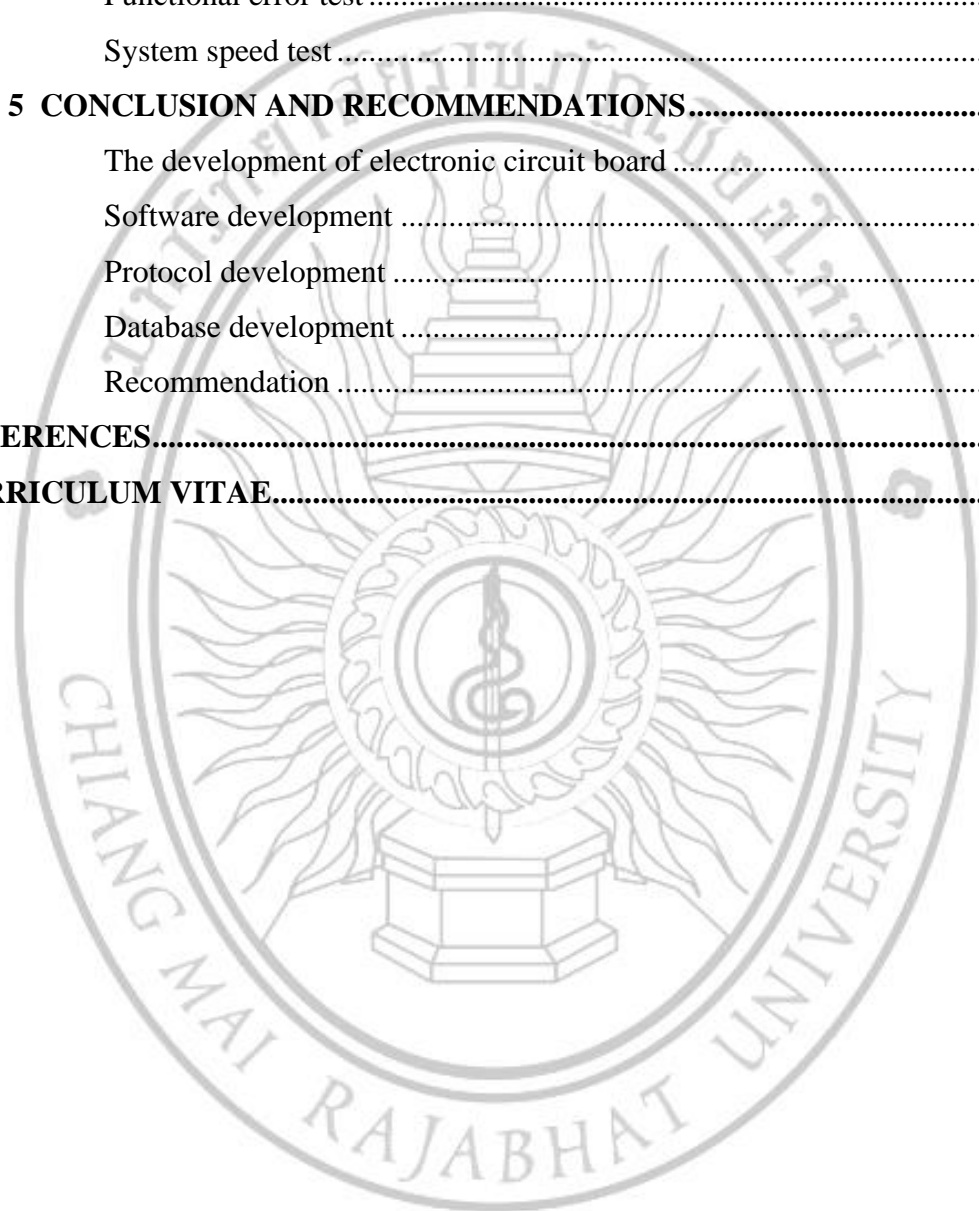


## TABLE OF CONTENTS

	<b>Page</b>
<b>ABSTRACT</b> .....	<b>II</b>
<b>ACKNOWLEDGEMENTS</b> .....	<b>IV</b>
<b>TABLE OF CONTENTS</b> .....	<b>V</b>
<b>LIST OF TABLES</b> .....	<b>VII</b>
<b>LIST OF FIGURES</b> .....	<b>VIII</b>
<b>CHAPTER</b>	
<b>1 INTRODUCTION</b> .....	<b>1</b>
Background and significance of the problems.....	1
Research objectives.....	5
Research scope.....	6
Definition of terms.....	6
<b>2 LITERATURE REVIEW</b> .....	<b>7</b>
Review of concept, theory, and related principle .....	7
Review of related literature.....	18
Database system.....	22
<b>3 RESEARCH METHODOLOGY</b> .....	<b>25</b>
The design of operating principle of the system.....	25
A process description of designing the working principle for online systems.....	38
Database design .....	41
Hardware development system design.....	48
Display screen design .....	53
<b>4 RESULTS AND DISCUSSIONS</b> .....	<b>68</b>
Hardware design and development.....	68
Accuracy of the display screen .....	78
Data display via a web browser .....	80
Mobile data display.....	91

## TABLE OF CONTENTS (Cont.)

<b>CHAPTER</b>	<b>Page</b>
Functional error test .....	94
System speed test .....	101
<b>5 CONCLUSION AND RECOMMENDATIONS.....</b>	<b>109</b>
The development of electronic circuit board .....	111
Software development .....	112
Protocol development .....	114
Database development .....	115
Recommendation .....	117
<b>REFERENCES.....</b>	<b>119</b>
<b>CURRICULUM VITAE.....</b>	<b>131</b>



## LIST OF TABLES

<b>Table</b>	<b>Page</b>
2.1 Ranking popularity of database systems 2019 .....	23
3.1 Example of data formats in MQTT.....	35
3.2 Process description 1.0.....	38
3.3 Process description 2.0.....	39
3.4 Process description 3.0.....	39
3.5 Description of process 4.0.....	40
3.6 Process description 5.0.....	40
3.7 User information .....	43
3.8 Group members.....	44
3.9 Friend information .....	44
3.11 Plug groups .....	45
3.12 Total electricity consumption statistics.....	45
3.13 Plug information .....	46
3.13 Electricity usage statistics per time.....	46
3.14 Events Log.....	47
4.1 Hardware function testing.....	73
4.2 Testing of control system errors .....	75
4.3 Determining the accuracy of the voltage measurement system.....	77
4.4 Accuracy testing of the electrical current measurement system.....	78
4.5 Website test schedule.....	79
4.6 Hardware system errors .....	94
4.7 Online program error tests .....	95
4.8 System administrator error.....	97
4.9 Testing the accuracy of the notification program.....	98
4.10 Control testing .....	99
4.11 Database errors test at different time interval.....	100
4.12 Hardware transmission time test table.....	102



## LIST OF FIGURES

<b>Figure</b>	<b>Page</b>
1.1 Solar electricity generation system .....	2
2.1 Arduino WiFi shield 101 .....	10
2.2 Arduino GSM shield 2 .....	10
2.3 3G/GPRS shield over arduino.....	11
2.4 Arduino MKR1000 WIFI .....	12
2.5 ESP8266.....	12
2.6 INA219B.....	14
2.7 Hall effect and hall effect sensor .....	15
2.8 Principles of voltage divider .....	16
2.9 Principles of MQTT protocol.....	17
2.10 Smart plug components.....	19
3.1 Working principle of smart plugs .....	26
3.2 Hardware operating system.....	28
3.3 The working principle of level diagram.....	29
3.4 Context diagram of online working principles .....	30
3.5 Level-0 diagram of online system work .....	31
3.6 Process 1 of level-1 diagram.....	32
3.7 Process 2 of level-1 diagram.....	33
3.8 Process 3 of level-1 diagram.....	34
3.9 Process 4 of level 1 diagram.....	36
3.10 Example of data transmission of smart plug.....	37
3.11 Process 5 of level 1 diagram.....	37
3.12 Smart plug system database .....	42

## LIST OF FIGURES (Cont.)

<b>Figure</b>	<b>Page</b>
3.13 Smart plug electrical circuit.....	48
3.14 Electrical circuit cutting.....	49
3.15 Current sensor circuit.....	49
3.16 Voltage sensor cutting.....	50
3.17 Button and status light.....	52
3.18 Websites structure.....	53
3.19 Web layout.....	54
3.20 Quick menu.....	55
3.21 Warning message.....	56
3.22 Member profile picture.....	56
3.23 Sidebar menu.....	57
3.24 Section name.....	57
3.25 Web content display.....	58
3.26 Window for show plug data.....	59
3.27 Window for add plug to group.....	59
3.29 Window for add plug to database.....	60
3.29 Window for adding group data.....	61
3.30 Window for show group data.....	61
3.31 Window for add plugs to the group.....	62
3.32 Plug control.....	63
3.33 Order button.....	63
3.34 Historical electricity usage.....	64
3.35 Friend search page.....	65
3.36 Windows success in finding friends page.....	65
3.37 Friend management page.....	66
3.38 Login.....	66
3.39 Resgister.....	67

## LIST OF FIGURES (Cont.)

<b>Figure</b>	<b>Page</b>
4.1 Schematic diagram of smart plug .....	69
4.2 Window for electric circuit design.....	70
4.3 Front circuit board.....	71
4.4 Back circuit board.....	71
4.5 Smart plug PCB board .....	72
4.6 Smart plug box.....	72
4.7 Main page.....	80
4.8 Quick menu.....	81
4.9 Notification menu .....	81
4.10 Profile settings .....	81
4.11 Side menu.....	82
4.12 Smart plug control page.....	82
4.13 Smart plug information page as specified by the user .....	83
4.14 History of electricity usage page.....	83
4.15 Group details page .....	84
4.16 Example of adding a group.....	84
4.17 Group management page .....	85
4.18 Example of adding smart plug to a group.....	85
4.19 Example of adding members to a group .....	86
4.20 Plug settings page for adding plugs into the system.....	86
4.21 Profile edit page .....	87
4.22 Friend management page.....	87
4.23 Finding friend system .....	88
4.24 Function finds members found .....	88
4.25 Example add member already.....	89
4.26 Notification page.....	89
4.27 Notification message details .....	90

**LIST OF FIGURES (Cont.)**

<b>Figure</b>	<b>Page</b>
4.28 Login page .....	90
4.29 Membership page.....	90
4.30 Main page.....	91
4.31 Side menu.....	91
4.32 Plug control.....	91
4.33 historical statistics.....	91
4.34 Electricity statistics.....	91
4.35 Add plug page.....	91
4.36 Group data.....	92
4.37 Add group information page.....	92
4.38 Plug management page.....	92
4.39 Friend Info .....	92
4.40 Friend finder window.....	92
4.41 Find Friends success.....	92
4.42 Friends search .....	93
4.43 Login page .....	93
4.44 Register page.....	93
4.45 Control transmission time Results .....	103
4.46 Data transmission time using JSON format and MySQL via internet 1 Mbps.....	104
4.47 Data transmission time using JSON format and MySQL via internet 4 Mbps.....	105
4.48 Data transmission time using JSON format and MySQL via internet 30 Mbps.....	105
4.49 Data transmission time using JSON format and MySQL.....	106
4.50 MySQL and InfluxDB data retrieval time .....	107

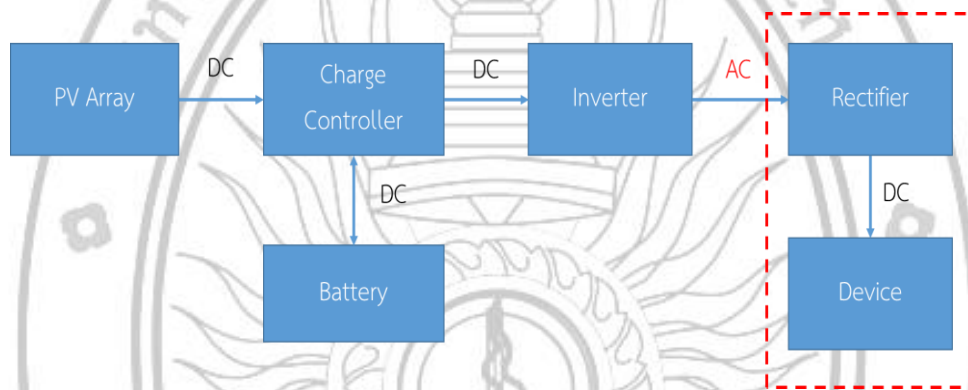
# CHAPTER 1

## INTRODUCTION

### **Background and significance of the problems**

Referring to statistical data of Global Statistical Yearbook (2016), it was found that human consumption of electricity is as much as 20,568 TW per hour. In addition, the demand for electricity is increasing year by year. Therefore, the supply of energy to meet the electricity needs of human is difficult. At present, 66% of electricity generation technology derives from coal and natural gas. Based on this information, we know that human use fossil fuels to generate electricity, because fossil energy is stable and contains lower production costs than electricity produced from other technologies, but it must exchange with a large amount of carbon dioxide emissions into the atmosphere (Raupach et al., 2007; Salahuddin, Alam, Ozturk, & Sohag, 2018; Shaojian Wang, Li, & Fang, 2018). In regard to such information, we know that the annual carbon dioxide emissions of the Energy Sector as high as 31,571 MtCO<sub>2</sub> in 2016. Thailand is another country that relies on electricity production using fossil fuels. Thailand produces 90.7% of electricity from MtCO<sub>2</sub>, natural gas, coal and oil, resulting in the release of carbon dioxide into the atmosphere up to 256.44 MtCO<sub>2</sub> when comparing to the Industrial Sector in which we understand that it emits high amount of carbon dioxide into the atmosphere. On the other hand, the Industrial Sector is emitting the amount of carbon dioxide at only 55.71 MtCO<sub>2</sub>. It can be seen that the Energy Sector emits 4 times of more carbon dioxide than the Industrial Sector or 82%. At present, we are aware of the situation of carbon dioxide emission into the atmosphere, which is one of the causes of global warming. Therefore, the Renewable Energy is continuously developed in order to help generate electricity for humans. There are many types of Renewable Energy. Solar Energy Technology is one of the Renewable Energy alternatives that can be easily applied. It is an easy and convenient technology to use,

because sunlight can be found anywhere in the world (Cai, Sam, & Chang, 2018; Kabir, Kumar, Kumar, Adelodun, & Kim, 2018; Rau & Baird, 2018) when comparing to other Renewable Energy such as Wind Energy and Water Energy which still requires the potential of the area to generate electricity. In addition, such energies also require high construction costs. For the reasons mentioned above, Solar Energy has become the most suitable alternative energy today. However, there are still many problems in applying Solar Energy Technology. In general, we prefer to use alternating current electricity (AC), but Solar Cells produce direct current electricity (DC). Therefore, it is necessary to install the electrical converters from DC to AC to make general electrical appliances to work as shown in Figure 1.1



**Figure 1.1** Solar electricity generation system

According to Figure 1.1, it can be seen that the system has to convert electricity from DC to AC and revert back from AC to DC which causing a lot of energy loss in electricity conversion. The process of converting the electricity back and forth results in a loss of energy from the conversion of electricity up to 25-30% (Reddy & Natarajan, 2018; Sahu et al., 2018; Su, Liu, Sun, Han, & Hou, 2018). Regarding to the case study prepared by Asian Development College for Community Economy and Technology (adiCET) has developed a production and distribution system of DC at voltage level 264-297 VDC. Such voltage level is the voltage that some electrical appliances can use DC directly and do not need to use the inverter anymore, in order not to lose power from converting AC to DC. The mentioned electrical appliances include computers, televisions, charging systems of electronic devices or electrical appliances with inverter circuits (Setthapun et al., 2015). According to the advantages

of producing DC, the researcher realized the importance of developing more efficient DC by controlling electrical appliances using DC to be able to operate by saving more electricity. Due to the electricity consumption behavior of electricity users affect energy saving. That is to say if there is an efficient electrical system but the user has bad electricity consumption behavior, then it will cause unnecessary losses. If the user has such behavior, although there is an efficient electrical system, it is not always enough (Guo et al., 2018; Wang, Lin, & Li, 2018). Implementing Smart Home Concept in controlling electrical appliances for the purpose of reducing unnecessary electricity consumption encourages electricity users to save more energy. Smart Home Technology is a technology that facilitates residents and able to control various electrical appliances in the home through the online system (Hargreaves, Wilson, & Hauxwell-Baldwin, 2018; Jensen, Strengers, Kjeldskov, Nicholls, & Skov, 2018; Piloni, Floris, Meloni, & Atzori, 2018). Smart Home system can also make automatic decisions to control unnecessary usage of electrical appliances, such as remaining open the light, turning on TV without existing audience, unnecessarily turn on the air conditioner, etc. The automatic system can help reduce such behavior and send alert to users as well as display the energy value of actual electricity usage by the user which allows users aware of wasteful electricity consumption behavior. Furthermore, if we use DC with advantages in energy saving to be applied to Smart home system, it will help to save electricity together with being more safety in using DC (Daly, Moore, Haddad, Specht, & Neal, 2018; Nguyen, Tran, Nguyen, Le, & Le, 2018).

The development of Smart Home system for DC relies on the study and development of electrical control systems for the advantage of ordering electrical appliances efficiently. However, the development of electronic control devices to control all home appliances is difficult, since each type of electrical appliances must use different control methods. Therefore, if developing a control device with capacity to control all electrical appliances in the home, it may need a lot of time and budget to develop such devices (Kumar, Verma, & Nagesh, 2019; Wu, Wang, & Wang, 2019). In this research, we studied the development of the plug system that is a connection point between the power supply and electrical appliances. Developing an Smart plug system will easily help control home appliances and be convenient for further development. The Smart plug system is therefore considered an important basic device

for the development of Smart home system in term of DC usage. The design and development of the power plug to suit the characteristics of DC must rely on electronic equipment to measure the current so that the plug can effectively control the operation of electrical appliances. Therefore, the power plug must consist of a sensor system that can measure current and voltage of DC so that the microcontroller or control board to use such data to analyze the results and decided to turn on/off electrical appliances in various cases, such as the case of over current, and electric surge, etc. We can program the microcontroller to calculate the electrical value to decide to switch off the operation of electrical appliances in such cases and send alerts to users via wireless transmission media through website and applications. Electrical data measured by sensors are also recorded in offline and online formats for easily applying data obtained for analysis the research results as well as displaying electricity usage statistics for users to know. The system can record the data into an online database for users and researchers to easily access information. The advantage of online recording system is that users can check their current and retroactive periods of electricity usage statistics. In addition, online recording system can also help researchers to readily access information, because the information about the use of electricity and electricity values can be used for analyzing the results in order to improve the system to be effective, as well as able to detect the system's defects.

This research focuses on applying technology and knowledge in Electronic, Data transmission protocol, Cloud systems and Web application to apply together to create the Smart plug which is efficient, fast, cheap and safe. In addition, this research presents a prototype for further development in DC appliances control, measuring DC consumption with a small sensor, data transmission system for sensor networks, real time data display, including large database systems. Such technologies are important for renewable energy, because the disadvantage of renewable energy is the lack of stability in energy production. In addition, the power generation system needs to rely on nature, so it is not able to control production. Therefore, most renewable energy production systems depend on batteries and contain a high production cost. Implementing the information technology can help increase the efficiency of renewable energy with the expectation that good data management will help reduce unnecessary energy consumption or control the power generation system to meet the requirements



of costs reduction. It can be seen that information technology is essential to the development of renewable energy. However, the development of such technology is difficult and full of limitations, due to it needs to develop a stable communication system and database. This research therefore is a good example for the development of communication technology and a large database which is suitable for collecting data of electricity usage. Development of Smart plug control systems for DC has the strength of studying how to create prototype hardware that can measure and control DC, together with developing online communication and database systems, being able to support many connections, being able to send data quickly even working in an unstable internet signal, supporting automatic data record of communication, and being able to send a large number of data stored in databases to users fast. Furthermore, this research also demonstrates the advantages, disadvantages and limitations of technology and enables us to implement the research results to be further continue study in various ways, for instance, applying the device to collect data of electricity production, collecting the data of various sensors or industrial control system.

### **Research objectives**

The purposes of the study are (1) Develop electrical plugs for direct current (2) Develop control system (3) display the electricity consumption rate of electrical plugs via web and applications. The study includes the objective of performing the following activities.

1. To design and create the Smart Plug for DC,
2. To design and create a system to measure the Smart Plug Control System for direct current via web and application system, and
3. To design and create a system to collect data of energy consumption by online system

**Research scope**

To design and develop electrical plug for direct current at voltage level of 264-297 VDC with the capacity of cutting off the power supply when a short circuit occurs and when the plug uses electricity exceed the value of the user's setting.

1. To control electrical plugs via web applications, to display the rate of electricity usage and electricity values as follows:
  2. Voltage, electric current, electric power
  3. Expenses arising from electricity usage through the plug
  4. To record the electricity consumption rate and electricity values online via computer server.

**Definition of terms**

**Smart Plug** is an electronic device which can control (Turn on / Turn-off) Electrical appliances connected to the plug. The plug system can be connected to the internet system, allowing users to control electrical appliances online.

**DC Smart Plug** is a type of smart plug that can measure the power of direct current and alternating current. The system will cut off the operation immediately when connecting to AC power.

## CHAPTER 2

### LITERATURE REVIEW

A study of DC Smart Plug is based on theories and related research as presented below:

Review of concept, theory, and related principle

- Direct current and DC Micro grid
- Microcontroller and Wi-fi module
- Current and voltage sensor
- Wireless data transmission
- Online communication system

Review of related literature

- Electrical control system
- Wireless communication
- Database system

#### **Review of concept, theory, and related principle**

##### **Direct current and DC smart grid**

Direct Current (DC) or as we called galvanic current in the past refers to the electricity that flow by only one direction from the negative electrode of the power source through the electrical equipment and then return to the positive electrode of the power source again. DC can be divided into 2 types, namely 1) Steady DC and 2) Pulsating DC. Both types have different advantages and disadvantages depending on the application. The same disadvantage or limitation of both types of DC is that they will lose power quickly when being sent from a power station with further than 1 mile or 1.6 kilometers. Later, George Westinghouse (A.D. 1846–1914) found a solution to

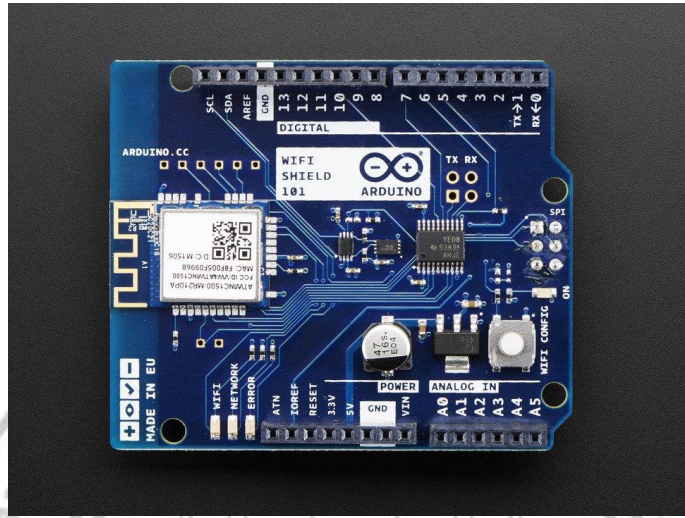
such problems and created an alternating current (AC) which could transmit electricity power for hundreds of miles by losing very little energy. However, DC was more popular at that time, because it was an era that electricity has just begun to spread to various sectors of society. DC produced from 121 power stations throughout the United States was sent to households. DC system is developed by Thomas Alva Edison (A.D. 1846–1931). Therefore, being a competition between AC and DC. However, due to the limitations of DC, it began to reduce popularity. Finally, AC has become a popular electricity used around the world (Andrews, 1974; Fairley, 2012; Hammerstrom, 2007). Afterwards, human beings have developed more efficient electrical systems to break down the limits of electricity and discover new methods to generate electricity with less cost and worth. Until now, there is the concept of intelligent electricity network or Smart Grid to use for maximum benefit of the electricity management. This concept cannot be clearly identified the truly designer or inventor, because there are different definitions and identifications in each country or in each department, thus the meaning of Smart grid in each area is not the same. However, we can still define the meaning from the same thing or the purpose of this idea referring to a system built as an electrical network which can connect each other independently and use information and communication technologies to manage, control the production, transmission and distribution of electrical energy. It includes the capacity of supporting the electrical system connection from Distributed Energy Resource (DER) and the asset management system for the maximum benefit as well as provide service to those who connect to the intelligent meter network effectively with stability, security, reliability and international standard power quality (Anuradha & Massoud, 2013; Bansal & Singh, 2016; Miller, Johns, Sortomme, & Venkata, 2012; Siebert, Troedson, & Ebner, 2001). Regarding to the above definitions, Smart grid system help the production and usage of electricity effectively and also be suitable for modern technology, for instance, Solar Technology, an energy source that people can access more easily than other alternative energy technologies, because it is a technology which users can install the system by themselves. The Solar System not only help reduce the government's burden of electricity consumption, but also reduce the electricity cost of installer. In addition, the Smart grid system has another function designed to support DC, called DC Smart Grid. It was created under a concept of reducing energy loss from electricity conversion

which makes the Smart Grid system be more effective and lower costs (Han, Wang, Sun, Yang, & Liu, 2017; Jin et al., 2016; Li et al., 2017). Due to it can reduce the number of electrical inverter as well as DC can be connected directly without any conversion which is easy to use. It's unlike the alternative current that needs to be converted to the frequency of the electricity to match with the power supply to be able to connect or put the electricity into the system (Judewicz, González, Echeverría, Fischer, & Carrica, 2016).

### **Microcontroller and Wi-Fi module**

Microcontroller (MCU) is a small control device that contains capabilities similar to computer systems. The microcontroller includes CPU, Memory and Port which are key components of the computer system together. MCU is used in specific tasks such as Motor control system, Automatic door system, Rainwater measurement station, etc. The reason that MCU is suitable for a specific task, because the MCU is cheap, small and able to add or reduce equipment or sensors as needed which is able to get rid of unnecessary things from the work piece. While the world entered the 3G era during the years 1999-2000, there is a competition to create products based on GSM-GPRS and other Time-Base protocols (Vujović, Maksimović, Perišić, & Milošević, 2015). Humans have more communication needs, so the need of things to facilitate human beings through the Internet is also increasing. Researchers and companies are starting to compete each other to meet that demand by developing the MCU system with full of advantages to be able to communicate via the Internet signal. The concept of Internet of Things or IOT was invented in 1999 by Kevin Ashton. He started the Auto-ID Center project at Massachusetts Institute of Technology (MIT) where required to develop RFID systems with the capacity to connect the whole world (Cui, 2016; Lee & Lee, 2015). The IOT concept is considered a concept that makes everything connected or makes electronic devices able to communicate with each other through the Internet. After the creation of IOT concept was happened and widespread, modern MCUs must be able to communicate with wireless systems or join to an accessory connected to a wireless system. Furthermore, currently there are many products with cheap and small to be used to develop equipment as needed. At present, the popular MCUs and accessories include:

## 1. Arduino WiFi shield 101



**Figure 2.1** Arduino WiFi shield 101, From “Adafruit products”

**Source:** Adafruit, 2019

Arduino WiFi Shield 101 is an auxiliary board for Arduino line. It can allow MCU connect to WiFi via IEEE 802.11 b/g/n standard. The data transfer speed is 72 Mbps. It supports Encryption types of WEP and WPA2 (Oliveira, Santos, & Neto, 2016).

## 2. Arduino GSM shield

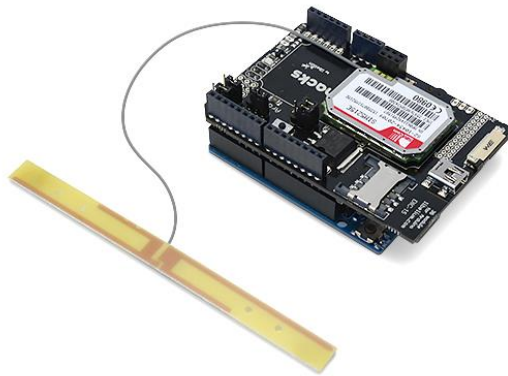


**Figure 2.2** Arduino GSM shield 2, From “Arduino store”

**Source:** Adafruit, 2019

Arduino GSM Shield 2 is an auxiliary board for Arduino - Uno Model which increases the ability for MCU to communicate with the Quad-band GSM/GPRS system. It supports frequency bands of GSM850MHz, GSM900MHz, DCS1800MHz and PCS1900MHz types. It can communicate through Protocols TCP/UDP and HTTP protocols. The data transfer speed is 85.6 Kbps (Rahman, Noor, Islam, & Salakin, 2015).

### 3. 3G/GPRS shield over arduino



**Figure 2.3** 3G/GPRS shield over arduino, From “Arduino store”

**Source:** Adafruit, 2019

3G/GPRS shield over Arduino is an auxiliary board for Arduino. It enables MCU to send data via 3G / GPRS. It supports data transmission through Protocol HTTP, HTTPS, FTP, FTPS, SMTP and POP3, connecting via frequency Dual-Band UMTS/HSDPA 850/1900/2100 MHz Quad-Band GSM/GPRS/EDGE 850/900/1800/1900 MHz. The data transfer speed is 384 Kbps (Vujović et al., 2015).

#### 4. Arduino MKR1000 WIFI



**Figure 2.4** Arduino MKR1000 WIFI, From “Arduino store”  
**Source:** Adafruit, 2019

Arduino MKR1000 WIFI is an MCU produced by Arduino. It developed the capabilities of the ARM MCU to be able to communicate with the WIFI signal via the IEEE 802.11 b/g/n standard. The data transfer speed is 32 Kbps, which is a very high speed. In addition, the MKR1000 is also designed to save energy. It consumes electric power only 3.5 VDC (Hanschke, Heitmann, & Renner, 2016).

#### 5. ESP8266



**Figure 2.5** ESP8266, From “Articles Internet of Things”  
**Source:** Gerd Wagner, 2019



ESP8266 is a cheap MCU manufactured Espressif Systems Company with the ability to connect with WIFI of IEEE 802.11 b/g/nESP8266 standard. In the first version, it was only Serial-to-WIFI working through AT Commands. Later, it became high popularity, so the company has developed many different MCU versions by enhancing the capabilities of programming through C ++ and Lua. The data transfer speed is 11 Mbps (Thaker, 2016).

### **DC current and voltage sensor**

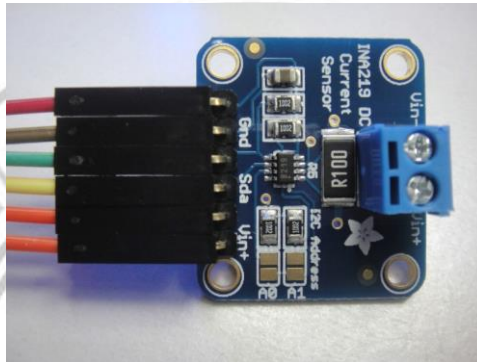
#### **1. Current sensor**

Measurement of DC in electronic circuits can be classified into 2 types, namely measuring the amount of current flowing through the Shunt Resistor and Hall Effect

##### **1.1. Shunt resistor**

Shunt Resistor is a measure of the voltage drop across the Shunt Voltage. It can be classified into two types namely High-Side measurement, the current measurement from the source before going through the electrical load and Low-Side measurement, the current measurement after passing the load to the GND of the system. Low-side current measurement is easier than High-Side, because electronic devices used are small and can be purchased in general. Low-side measurements use resistors with low resistance and low tolerances, such as 1% or 0.1%. When a current flows through the resistor to GND, the voltage drop will be happened. If measuring the voltage at that resistor using a circuit such as ADC (Analog-to-Digital Converter) inside or outside the microcontroller, it results in the voltage value. When dividing by the resistance, it results in the amount of current flowing at that time. High-Side current measurement also uses resistors and measures the voltage drop across the resistor. However, measuring the difference between the two voltage points requires a circuit that uses Differential Amplifier. The advantage of high-side measurement is that it can be used to measure the amount of Current Consumption by connecting GND to the source and the circuit together. At present, there are many companies that produce ICs as integrated circuits for high-side current measurement. It also includes an amplifier circuit, and often have Gain, such as in the range of 50 to 500, providing current output. When using, it must be connected to the GND resistor, then measure the voltage drop across the resistor or provide Voltage Output. Some ICs have integrated the ADC

circuit and can be digitally connected via the I2C bus. It will be easy to use with the microcontroller and INA219B IC. It is an example of a High-Side DC and results in the values via the I2C bus.



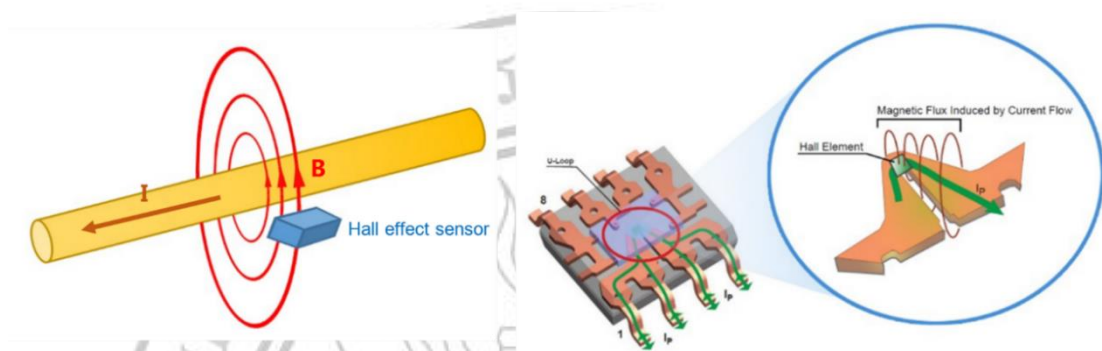
**Figure 2.6** INA219B, From “Protosupplies Products”

**Source:** Protosupplies, 2019

Referring to Figure 2.6, it is an example of using INA219B. This IC number can measure electricity consumption at  $\pm 3.2\text{A}$ , applicable to Voltage up to 26 VDC. INA219B is easy to use, no need to calibrate. The only one disadvantage of this IC is that it supports Voltage at 26 VDC only, therefore it cannot be used with high voltage systems (Dezfouli, Amirtharaj, & Li, 2018; Huang & Shimizu, 2018; Kon & Yamada, 2015; Pacha, Varecha, & Sumega, 2018)

## 1.2. Hall effect

Hall effect is an indirect current measurement. When we supply electricity both DC and AC, it causes the magnetic field around the wire, and Hall Effect Sensor in the magnetic field lines send a signal through the measured magnetic field level, as shown in Figure 2.7.



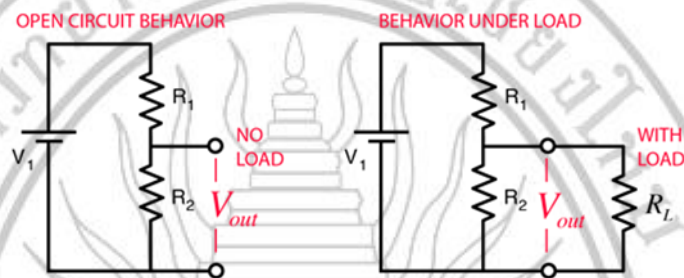
**Figure 2.7** Hall effect and hall effect sensor, From “Thaieasyelec”

**Sourec:** Thaieasyelec, 2019

Figure 2.7 is an example of the Hall effect phenomenon, a phenomenon that the charge moving in the conductor existing in a magnetic field, and move together on each side of the conductor causing the difference in electric potential between two sides of conductors which can be measured. We call the difference of electric potential that the Hall voltage. Referring to Figure 2.7, it can be seen that the sensor itself send Hall voltage out through the Output Port. The sensor users needs calculate the current value from the obtained voltage by themselves. Each sensor provides different value of Hall voltage. That’s mean there are different kinds of Measuring Rang and Sensitive in each sensor depends on the characteristics of item to be measured. The disadvantage of Hall Effect Sensor is that if you want to use it for measuring the work consuming a lot of electricity. For example, when we use Sensor 50A to measure the current of 1-3A range, it will result in not fine value or a high error. Therefore, we must choose the sensor to suit the work (Galera & Llantos, 2017; Nandipati, Babu, Chigurupati, & Vaithilingam, 2017; Sharon, Khachatryan, & Cheskis, 2018; Su, Fu, Wan, Zhang, & Ma, 2019).

## 2. DC voltage sensor

There are many methods to measure the DC Voltage. The Voltage Divider Circuit is another method applied to detect Voltage and also able to measure both AC and DC. Voltage Divider Circuit is the method of bringing the two resistors to join series each other between the power supplies, then the resistors in the circuits divide the voltage. The Voltage Divider Circuit can be divided into 2 types, namely 1) Unloaded Voltage Divider and 2) Load Voltage Divider, as shown in Figure 2.8.

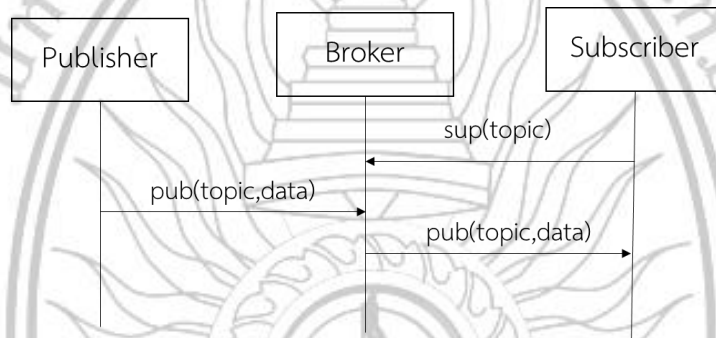


**Figure 2.8** Principles of voltage divider

Figure 2.8 is an example of a Voltage Divider Circuit. In order to apply it for work depends on the Voltage output of the Voltage drop between the resistors to continue work. Both types of Voltage Divider Circuit will result different voltage output. The value of Load Voltage Divider will be changed when the value of Load and Voltage input change. As for the value of Unloaded Voltage Divider change is consistent with the change of Voltage input. From the electrical principle of Unloaded Voltage Divider, the output is variable corresponding to Input. Therefore, we can apply this principle to convert Voltage Input to be Voltage of 0-5V, then convert such data into the Digital values. Then we can create Voltage sensor from the theory of Voltage Divider Circuit (Galliana, Capra, Cerri, & Lanzillotti, 2018; Kovačević, Stanković, Kartalović, & Lončar, 2018).

### Online communication system

MQTT (Message Queuing Telemetry Transport) is a protocol designed for M2M Communication (Machine to Machine). It was originated by IBM and Eurotech's engineers in 1999 for using in SCADA (Supervisory Control and Data Acquisition) system for the purpose of connecting the oil pipelines on unstable network like satellite internet. In 2014, it was donated to be Open Standard called OASIS MQTT, a Client/Server architecture which has a hub-and-spoke topology. The destination sensor acts as a client to create a TCP connection to the server, called Broker which acts as a data transmission pipelines for transmitting messages between clients both Publisher and Subscriber, as showed in Figure 2.9.



**Figure 2.9** Principles of MQTT protocol

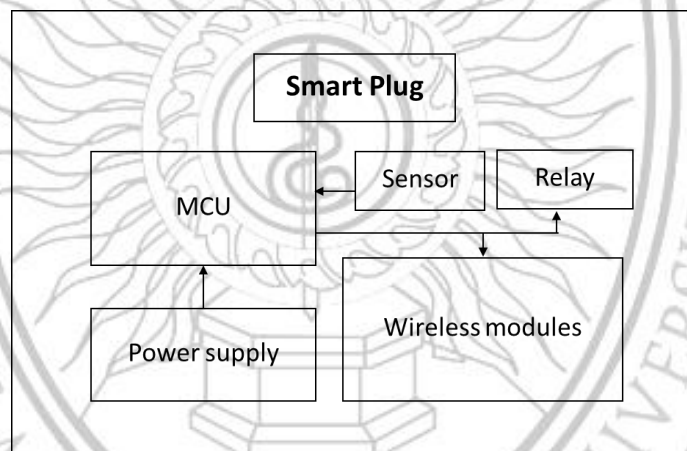
Regarding to Figure 2.9, it describes the method to transmit data between the Client to the Broker. The client refers to Publisher or Subscriber which centrally connecting to the Broker. It is a software that receive all messages from the Publisher, and then relay those messages to the subscribers according to each topic that the client has subscribed. The topic is like the address or end point on the Broker that the client was connected to transmit the data each other (Al-Fuqaha, Guizani, Mohammadi, Aledhari, & Ayyash, 2015; Hunkeler, Truong, & Stanford-Clark, 2008).

## **Review of related literature**

### **Electrical control system**

In current technology, there are various methods of controlling the electric appliances. The human have tried to create the most effective technology to control each type of them. However, there are many different definitions of effectively control in each study. For instance, the research of Dae-man Han (2010) focused on the development of hardware system which is able to transmit data accurately and quickly. The research conducted the study to create equipment for controlling air conditioners and electric lamps. The system is able to control such electric appliances by transmitting wireless data via Zigbee, a low cost and low power wireless communication. In addition, this research also applied IEEE 802.15 standard which caused the system control is more effective. Regarding to the research of Maytham (2015), he developed a Smart plug which can measure the electricity consumption rate and also control the electric appliances via wireless signal. His research is similar to the research of Dae-man Han focusing on the development of effective data transmission system using Zigbee. In addition to paying attention to the data transmission, his study is interested in the development of energy measurement system using IC ACS712 to measure the electric current and use electronic transformers to measure the voltage. It enables users to retrieve the information of electricity consumption rate of the plug. In order to develop the system to support Real-time display to users still have limitations, due to the data transmission for general data is not good. It depends on the data transmission system or effective Gateway to help manage the data transmission process, so it is able to transmit the Real-time data (Dorri et al., 2017; Santoso & Vun, 2015; Wu, Liao, & Fu, 2007). Later, Valtchev (2002) has developed a Gateway called Service Gateway Initiative (OSGi). This research designed principles and data transmission methods to orderly manage data traffic. It allows controlling of many electric appliances as easier and faster. The research results confirmed that the system development of data transmission enables us to control electric appliances well and also control system operating online such as web or applications effectively (Dunfan, Daoli, & Wei, 2009; Li, Zhang, Peng, & Huang, 2009). In addition, in order to increase the efficiency of the control system, it needs to rely on the design of working principles or control system architecture to be in line with the limitation of the Hardware system. Due to the

Hardware and electronic devices contain many limitations and inflexibility, such as memory size, speed of clock signal and the form of wireless data transmission, etc. The research of Cook (2003) has developed the architecture of control system called MavHome Architecture. This research has developed an architecture that enabled electrical control system to work better and reduce necessary procedures which caused the overall system effectively control electric appliances. Experiment results of implementing MavHome with Smart Home devices caused sensor system and various controller devices installed in the sample houses is able to control electric appliances precisely without error occurring. Therefore, proper architecture design can increase the efficiency of electric appliances control. The review of relevant literature can be concluded that the development of effective electrical control system concerns 3 parts to consider, namely 1. Hardware system that must be able to control electric appliances and connect to wireless signal. The various components include the following details as showed in Figure 2.10.



**Figure 2.10** Smart plug components

Figure 2.10 is an example of a basic device that a smart plug required. The system includes MCU Sensor Relay Wireless modules and Power supply. Those systems will work together while MCU will process the data from sensor detecting the electricity consumption rate, along with exporting the results of processing to the Relay used for electronic circuit cutting. It enables the system to turn-on / turn-off the electrical equipment connected to the Smart plug. MCU will send and receive the data

from Wireless modules, which allow users can control and monitor the electricity consumption rate of electronic devices connected to the Smart plug. As for the Power supply serves to convert electricity and distribute the electricity to the Smart plug as its energy source. 2. Software system which allows users to control electric appliances quickly and safely. 3. Protocol and Gateway to help and resolve the limitations of each technology applied. All of above 3 components are important for developing a Smart plug system for DC.

### **Wireless communication**

Electrical control system is a collaborative system between Hardware, Software and Network used for controlling turning-on / turning-off the connected electric appliances. The study was found that the development of electrical control system has been developed widely and had different advantages and disadvantages. Other researches often focus on creating a hardware system which is able to control the electric appliances effectively. However, there are many limitations of creating the electrical control system, including the size of control device must be small, data transmission control via wireless signal and security, etc (Areed, 2019; Marikyan, Papagiannidis, & Alamanos, 2019; Shin, Park, & Lee, 2018). There are many researches tried to fix these limitations. Each research used different methods and technologies. Regarding to the development of Smart Home Appliance Control System for DC, the researcher is interested in studying the wireless signal control system using technology that allow the MCU system to communicate with wireless system as it is an important medium serving to transmit user's command to the Smart Plug. If there is a good communication system, the electrical control system will be more effective. However, the development of MCU to be able to transmit data via wireless signal includes various appropriate technologies which has different advantages and disadvantages. The review of related literature therefore studied the examples of popular technologies used. The research was found that the Wireless communication affects the quality of Smart plug system control, due to the size and quality of data related to the speed of control. If there is powerful Hardware and Software, but poor wireless communication, then the overall system will be also ineffective (Chen & Pomalaza-Raez, 2009; Gungor & Korkmaz, 2012). Regarding to the research topic of Data Quality in Smart Home, there is a delay value test of the data transmission via



Wifi Signal by installing the different types of in-house control devices in 6 houses. We have known that the house appearance affects the quality of the wireless signal and causes less speed of the data transmission to online system. Therefore, it is concluded that the quality of wireless signal directly affects the speed of data transmission via Internet (Deese & Daum, 2018; Leonardi, Ziekow, Strohbach, & Kikiras, 2016; Vanus, Kucera, Martinek, & Koziorek, 2014; Viani et al., 2013). The development of a protocol results in Wireless communication system work faster or better. When low quality of wireless signal, it cause Smart plug more efficient. At present, there are many technologies to choose, but the popular system is the data transmission via Zigbee, the data transmission standard via wireless signals which able to transmit data far and save energy. The research of Fernández (2015) has designed the working principles of Smart plug system using Zigbee-based. It was found that it can control electric appliances quickly. However, Zigbee cannot connect to Internet system directly, so it is necessary to have a gateway system to convert Zigbee signal to connect to Internet, causing the delay in this process. Regarding to the research of Ding (2016), he studied the creation of Smart Gateway architecture system. It refers to the standard and methods of communication via Internet system. The connection of Smart Home System, the researcher was found that the system using Smart Gateway had increased speed from the original system, more safe energy in data transmission process and be able to connect a variety of electric appliances, for example of security camera, sensors and electric appliances. In addition, the research has developed the security for the system, it can prevent someone who try to hack the system. Regarding to the additional review of literature, if we can develop a Gateway working on a high-speed Internet system, like 4G or 5G system, the data transmission will increase efficiency as well. In regard to the research of Lynggaard (2015), he has studied the application of high-speed connection technology with 5G technology. In the research, the technology has been applied to the Smart Home Gateway System which results in a faster working when comparing to the original technology. For instance, Xin (2014)'s study that developed the study of electrical control system via GSM for communication. GSM is a global used digital mobile phone system. The program relies on sending SMS via the GSM Network to the control system. Then, the control system will receive the user's command as well as process to turn-on and turn-off the electric appliances according to

user's requirement and send the SMS back to the mobile phone that send SMS to it. In comparison, the 5G Gateway system has a speed of more than 60 times. Based on above mentioned literature reviews, it is known that if we need to develop an efficient Smart Plug system, the system can be connected to Internet directly and also connected to an effective Gateway or contain Service system that allow Smart plug to work better. In this research, the researcher applied MQTT Protocol to help the Wireless communication system of the control and result in effective Smart Plug. This is because MQTT is an Open source allowing us to develop Gateway system specially used for Smart plug. In addition, the study let us develop 2 programs to help accelerate the speed of MQTT by using MySQL Database to cooperate with MQTT. It helps reduce the size of data used for transmission process. Since we can divide some data to store in the database to reduce the size of command set sent via MQTT Protocol. When we have less size of command set, it will result in more speed. MQTT contains a very small format of data transmission and low bandwidth. It works well when operating with low speed internet or low quality of wireless signal (Al-Fuqaha et al., 2015; Lee, Kim, Hong, & Ju, 2013; Shofa, Rakhmatsyah, & Karimah, 2017). The application of MQTT Protocol to Smart Plug System therefore is very appropriate.

### **Database system**

Database System is a system collecting various relating data together orderly, as well as having a clear relationship between various data. The database system include many files relating to each other in a systematic matter. It allows users to use and maintain this data effectively. It includes Software conducting like a medium between users and programs relating data usage called DBMS (data base management system) It helps user to access the data easily and conveniently. User's data access may be the action of creating, editing or asking question to achieve data. The users don't need to know the details inside the database structure (Abouzeid, Bajda-Pawlikowski, Abadi, Silberschatz, & Rasin, 2009; Stonebraker et al., 2005; Subramanian et al., 2010). However, there are various formats of database systems developed by companies as specifically applied work. Therefore, the method of database using includes different command forms or database types. As example shown in table 2.11, representing the database name, database type and database popularity.

**Table 2.1 Ranking popularity of database systems 2019**

Rank	Database name	Database Model	Popular score	
			2018	2017
1	Oracle	Relational DBMS	1309.12	-49.97
2	MySQL	Relational DBMS	1180.48	-132.13
3	Microsoft SQL Server	Relational DBMS	1051.28	-161.26
4	PostgreSQL	Relational DBMS	406.43	34.07
5	MongoDB	Document store	358.79	26.06
6	DB2	Relational DBMS	181.06	-17.28
7	Elasticsearch	Search engine	142.61	22.61
8	Redis	Key-value store	140.94	20.54
9	Microsoft Access	Relational DBMS	133.39	4.58
10	Cassandra	Wide column store	119.55	-6.65
11	SQLite	Relational DBMS	115.46	3.42
12	Teradata	Relational DBMS	77.38	-3.52
13	Splunk	Search engine	74.03	11.45
14	MariaDB	Relational DBMS	70.64	15.17
15	Solr	Search engine	60.2	-9.71
16	Hive	Relational DBMS	59.63	-11.02
17	HBase	Wide column store	58.47	-5.87
18	SAP Adaptive Server	Relational DBMS	58.04	-8.71
19	FileMaker	Relational DBMS	55.3	-5.69
20	Amazon DynamoDB	Multi-model	53.34	15.52

**Note.** Ranking popularity of database systems

**Source:** db-engines, 2019

Referring to Table 2.1, it is the world's most popular database, rated by db-engines. It is a website created by Solid IT, an Australian IT consulting company which focusing on Software development, consulting and training for database application. The score calculation is made from the number of search result in Google Bing Yandex, answering and questioning in the IT website, talking in social networks and information

in job service website. Then DB engines.com will collect the obtained information to process and provide a score. The statistical data will help us to limit the scope of the study to know the pros and cons or able to find database to suit the work. The study result was found that the suitable database system for using in the system of electricity consumption rate includes 2 types, namely MySQL and InfluxDB. They are different as well as contain advantages and disadvantages. MySQL is a Relational Database Management System. It store all data in table form instead of storing all data into a single file, causing it works fast and flexible. In addition, each data table can be connected together which enable users to combine or categorize the data as needed. Therefore, it is suitable to be used to store data of various sensors in the kind of repeated data storage. It is also popular used for storage of various sensors, for example of Ferdoush (2014)'s research that studied about data storage, temperature, and humidity via wireless signal. The experiment results showed that MySQL can be used to store the data of sensors. In addition, it is also popular used to store the data of electricity consumption rate. Referring to the research taken by Stojkovic (2006) that used MySQL for storage the data of electricity consumption rate of SCADA system in Montenegro. However, MySQL still has a limitation that is its speed will be decreased when retrieving large amount of data. It is different to influxDB which supports large data. As the influxDB is a Time Series database. It is data arrangement according to the time consecutively. It can retrieve data by just specify the time of requesting data, the the database system will export the data as required. However, the disadvantage of influxDB is that it cannot be applied to complex tasks or having a joint relationship (Chen & Han, 2018; Singh, Jha, Ranjan, & Tripathy, 2015). Therefore, InfluxDB requires the ability of the database to help remove such limitations out. The research of Balis (2017) that takes 4 types of databases, including MongoDB document database, PostgreSQL relational database, Redis dictionary data server and InfluxDB time series database to apply with real-time Environmental sensing. It use the obtained data to analyze for creating a system to support decision making and providing an early warning. Such research implemented the advantages of each database to coordinate each other in order to achieve the speed of processing the large amount of data.

## CHAPTER 3

### RESEARCH METHODOLOGY

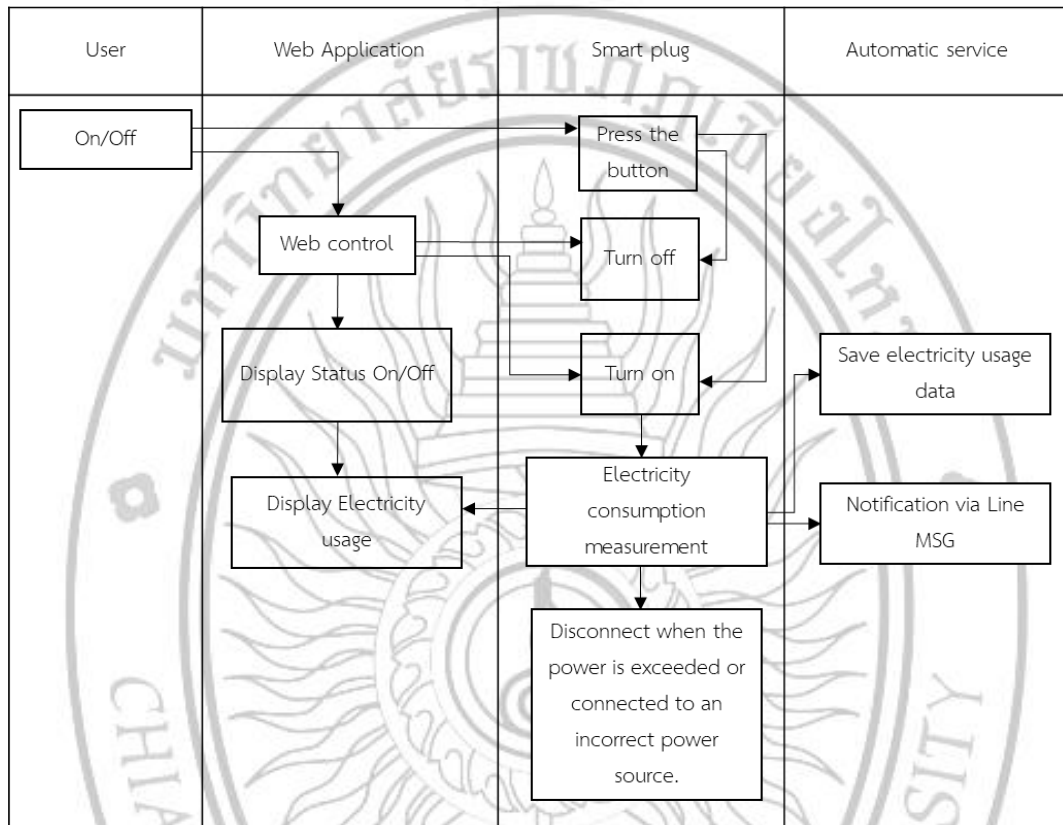
DC Smart plug system has been developed to increase the efficiency of using direct current (DC) effectively and more safe. The feature of the plug depends on the interoperability between hardware system of the plug and software operating online. Both systems are designed to work separately, but still be synergetic to support the safety of users and devices connected to the plug. The system design is developed to support the instability of the wireless signal system. The plug security system must always be workable even though it is disconnected from the internet. The development of the Smart plug system can be divided into 5 parts.

- System design principles
- Database design
- Hardware development system design
- Display screen design
- Designing methods of efficiency finding.

#### **The design of operating principle of the system**

Smart plug is a device installed between the power supply and electrical appliances. Its operating principle is able to control the on / off of electrical appliances connected to the plug with electronic devices. Users can control the plug by pressing directly on the button of the plug or control the plug through the website. The development of a smart plug system to be efficient and safe is important for system development process and considered the first priority. However, in regard to efficiency and safety are the basic requirements for electronic systems. It means that if any error occurs, it will affect the safety of life and property of the users. More details that Smart plug requires includes the plug must help user feels comfortable as much as possible.

Furthermore, a system can be used easily (Lin, Huang, Chen, Sung, & Yang, 2018; Ulloa, García-Santander, Carrizo, & Hurtado, 2018). The design of the operating principle of the Smart plug system is the core of the system in order to maximize the use of electrical energy and help users to have a comfortable life. The researcher has designed the basic application of the plug as described in Figure 3.1.



**Figure 3.1** Working principle of smart plugs

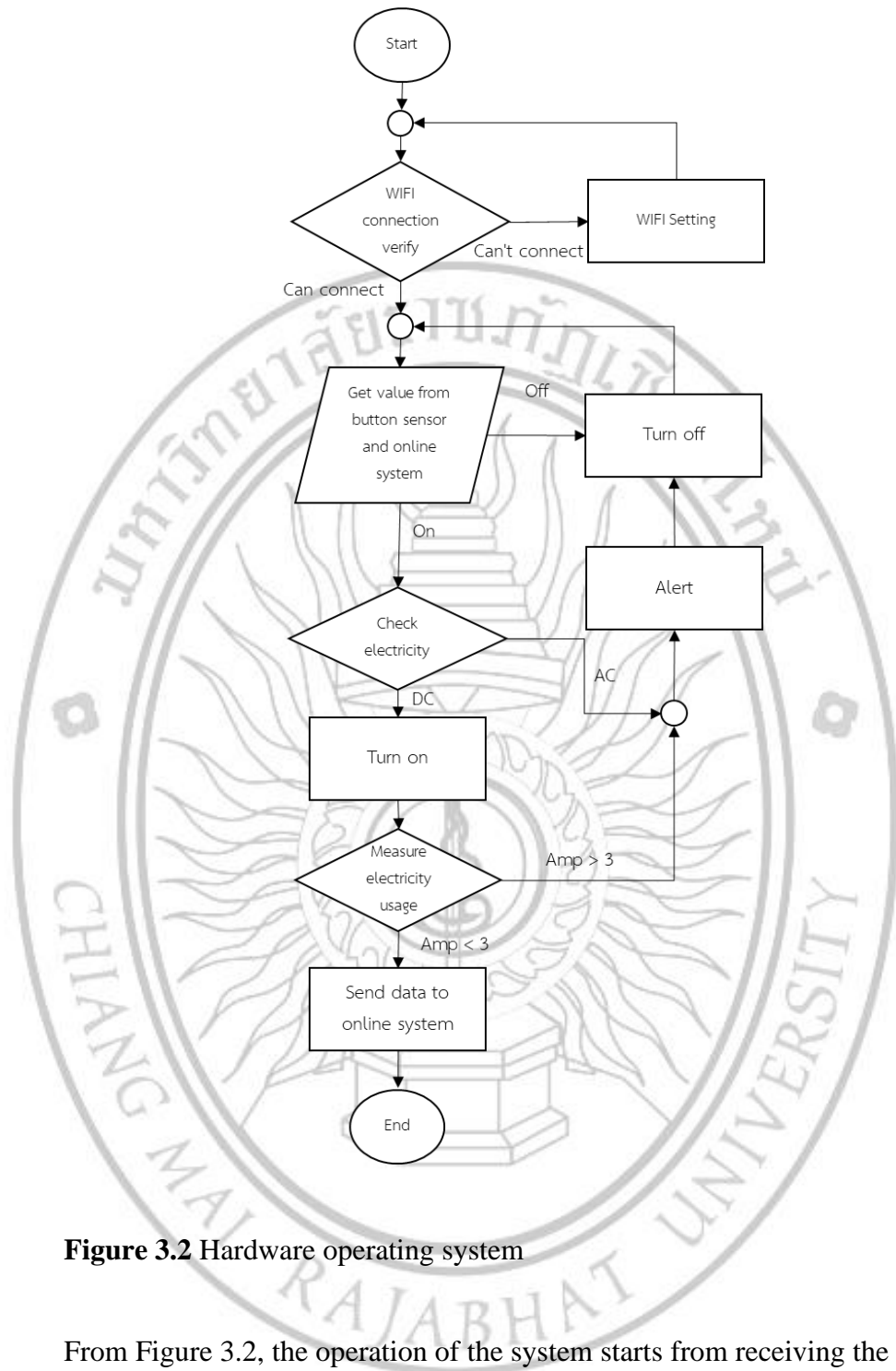
Figure 3.1 referred to the basic working principle of the system that the researcher designed for the most easy to use. Users just press the on / off button via the plug or the web application to control electrical appliances connected to the plug. When the system receives users' commands, the system will take the result to control the devices together with measure electricity usage, record results, and display the results online. If electricity is used exceed the limit set by the user. The system will send the alert messages via Line messenger to users. Or when users apply the Smart plug with

electricity that does not compatible with DC power, the system will automatically cut off the work.

From Figure 3.1 presenting about the design of the basic principles for the user interface, it can be seen that the system is not complicated, because the automatic system helps facilitate and also reduces unnecessary work. System development to be in accordance with the design of above mentioned working principles. The researcher has separated the work into 2 parts: The design of Smart plug system principles, and system design operating on the online system. The separation of such functions will help the system become more stable, because we must consider the instability of the internet system. The plug system must maintain working even it is disconnected from the internet. In addition, the online system must be able to check that the Smart plug is disconnected. Details of system development methods can be explained by the following topics:

#### **Working principles of hardware system in smart plug**

Working principles design of hardware system is to define the working principle of Smart plug to work according to the specified conditions. Such work can be explained as Figure 3.2.



**Figure 3.2** Hardware operating system

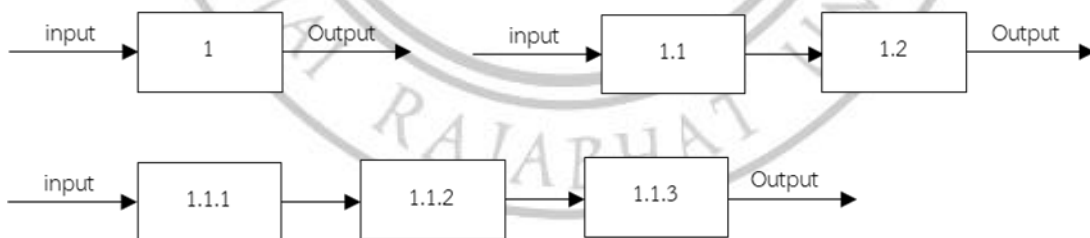
From Figure 3.2, the operation of the system starts from receiving the value from the keypad and data from the online system via wireless signal. The user can control the on / off plug through the push of a button and control it via the online web system. The system will check the command at all times and transfer such commands to the control device to cut the circuit through the Relay device. When the system checks that the user wants to activate, the system will recheck which type of power



supply that the plug is compatible to. If connecting to AC, the system will not allow the plug to work and alert the user. The system activate only when using a plug with DC using electricity for not exceed 3 Ah. When passing the above check, and nothing wrong found, the user will be able to activate the plug as usual as well as able to view the electricity consumption online.

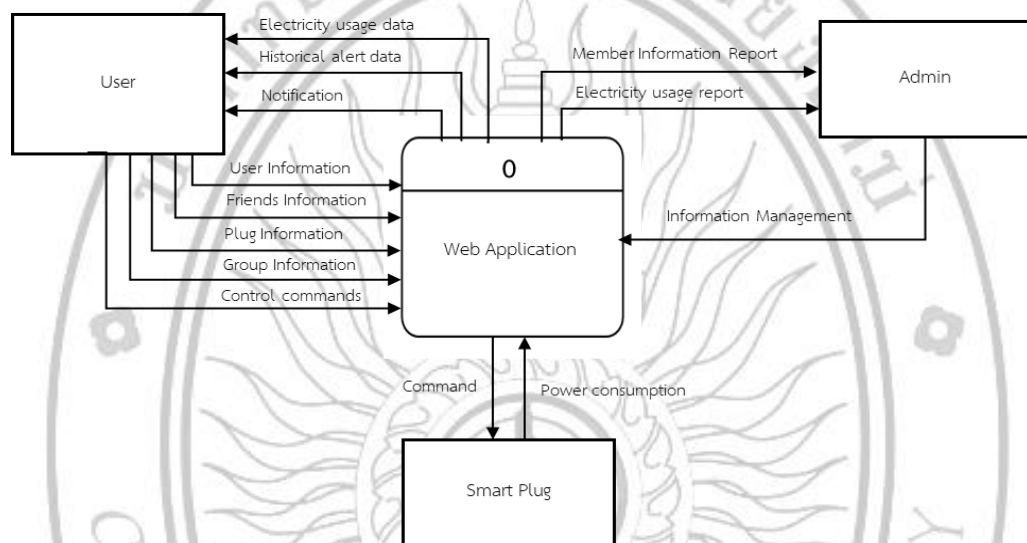
### **Designing the principles of online systems**

The designing the principles of online systems refers to the designing in methods of controlling, displaying and transmitting the data and storing the results into the database, which the system can work through automatic system. The working principle of online systems is very complex. The researcher therefore uses the Data Flow Diagram (DFD) to easily describe. DFD is an easy-to-understand diagram which is a widely used tool suitable for writing a highly complex simulation diagrams. The DFD diagram describes the communication principles during the work process. For example, describing the data transmission during the process, upon completion of the process, the data will be sent out to another process or record, delete or modify the obtained data, etc. The DFD implementation principle is divided into 2 parts including Context Diagram and Level Diagram. Context diagram is a diagram for describing the tentative working principle of the system. It enables readers to understand the overall image of the system works. As for the Level Diagram explains the methods of work thoroughly starting from Level-0 Diagram to display all the workflows of the system and divide into layers to explain the sub-contents, as shown in the example of Figure 3.3



**Figure 3.3** The working principle of level diagram

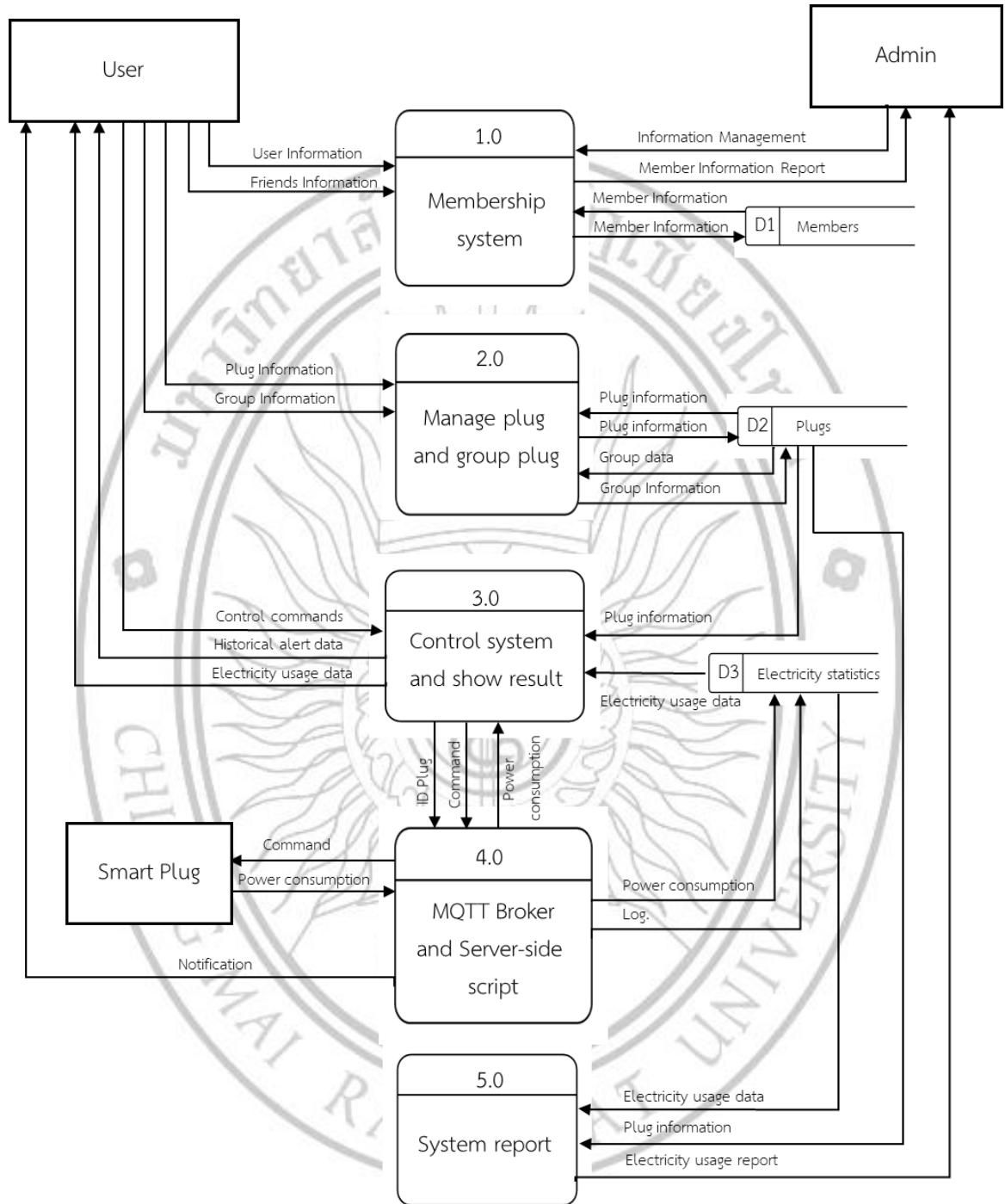
Figure 3.3 explains the operation of multiple systems existing in the same system. The subsystem is described by using the identification number. From the example figure, the number 1 diagram includes two working processes described as 1.1 and 1.2 procedures. In procedure 1.1, the work principle can be divided into another 3 sub-procedures and explain endlessly depends on how complicated the system is (Heayyoung, Omori, & Ohnishi, 2019; Sion, Yskout, Landuyt, & Joosen, 2018). As for the design principles of the online system is as shown in Figure 3.4.



**Figure 3.4** Context diagram of online working principles

Regarding to Figure 3.4, the working principle of the online system is to perform as a medium to transmit data from users to the Smart plug via the Web application system. Users can control the Smart plug via the web system and view the real time electricity usage statistics report or historical electricity usage statistics. The web system includes Smart plug function to reduce the workflow in the Smart plug. The system will automatically connect to the Smart plug after the user has set the Plug ID data correctly. In addition, the system also provides a channel for web managers to help facilitate users. In the event of a crash, the web manager will be able to help access some of the users' information systems. In case of extenuating circumstances, the web manager will be able to access into the system to resolve some part of the users'

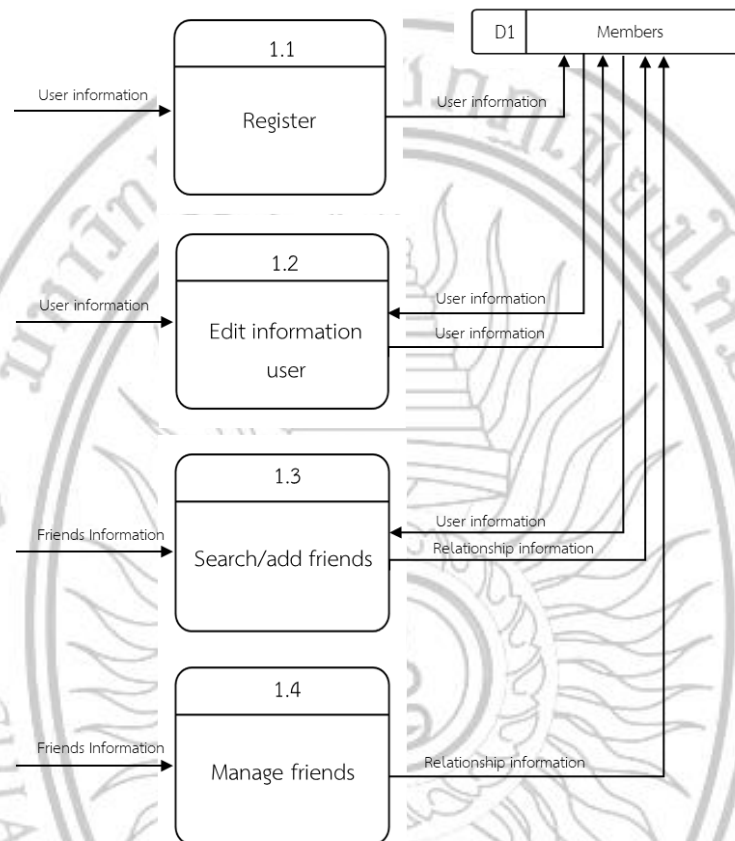
information. The working principle consists of 5 important parts working together which can be explained in Figure 3.5.



**Figure 3.5** Level-0 diagram of online system work

Figure 3.5 refers to a Level-0 Diagram describing the working principles of the online system. There are 5 functional sections that work together. Each section can be explained by the following topics.

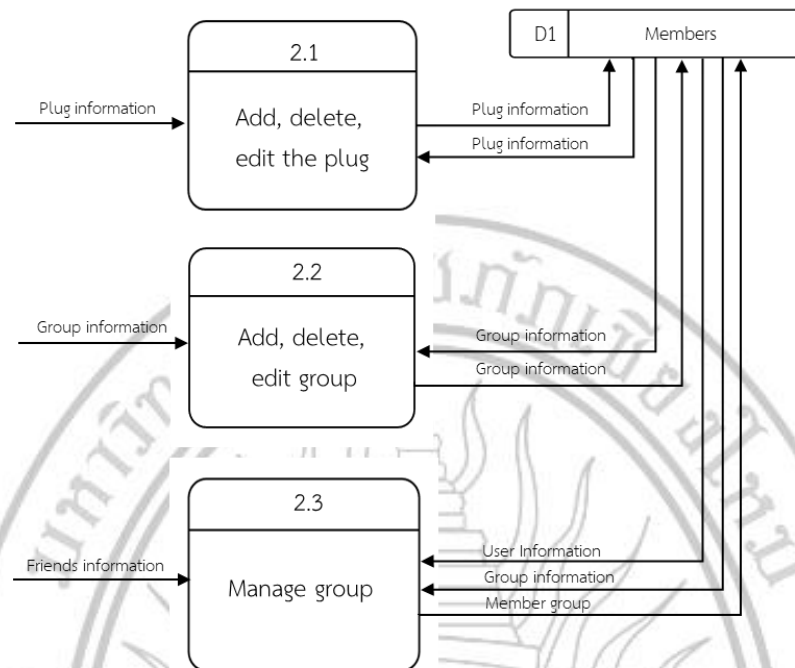
### 1. Member system



**Figure 3.6** Process 1 of level-1 diagram

Referring to Figure 3.6, the membership system performs to manage the subscription, editing or deleting membership information. In order to access such functions requires a login to verify user for getting the right of access. Once the access rights have been passed, then the users can modify the information. In the part of the general membership section, the system allows users to modify only their own identity. As for the web manager is entitled to the right of access to all members' information. Users can search for friends to connect relationships and can sharing the smart plug.

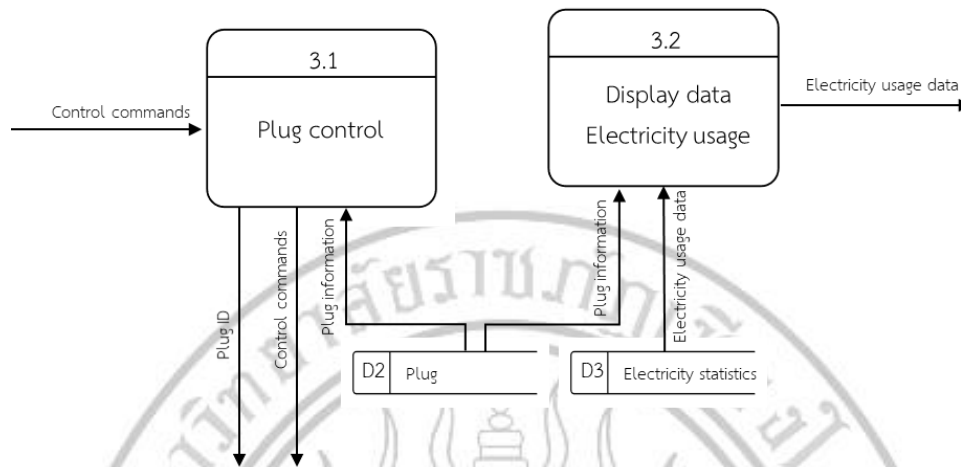
## 2. Plug management system



**Figure 3.7** Process 2 of level-1 diagram

Referring to Figure 3.7, the plug management system is a system used for setting the plug data to be connected to the system. Users can add, delete or edit the plug data. That one thing makes the Smart plug to connect with the system is that users need to know the Plug ID so that they can add plug-in data to the system. The Plug ID is a unique serial number which is not duplicated with other plugs. It acts as the address that allows the system to send data to that plug exactly.

### 3. Control and display system



**Figure 3.8** Process 2 of level-1 diagram

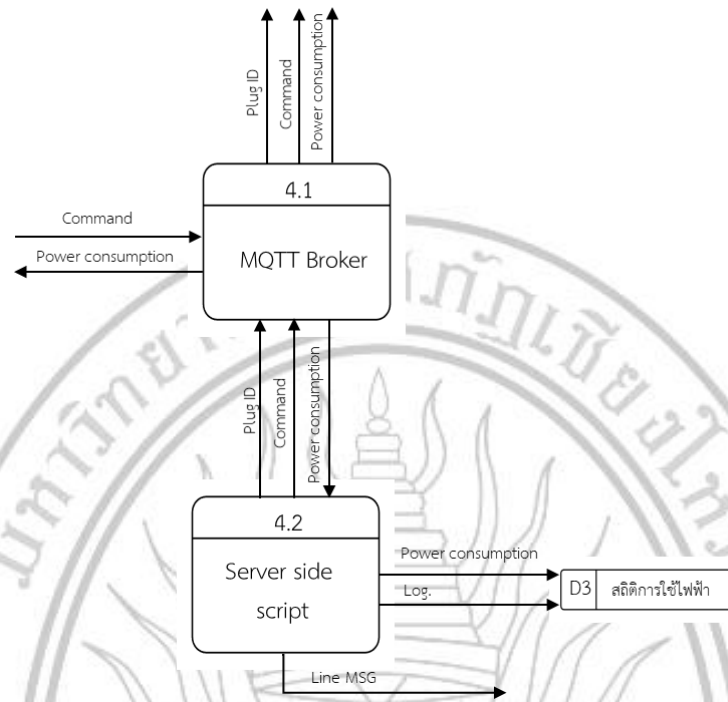
Figure 3.8 is a system used for communicating with users in order to control the plug and display data. The system work starts from user authentication, then transmit data to the control and display screens. The working principle in the control screen is to get the plug data from the database storing the details of the plug to display. At this algorithm, user is able to find their registered plugs only. After receiving the plug-in data, the system will recognize the Plug ID and wait until the user presses the control button. When the user presses the control button, the system will bring the command together with remembered ID plug submit to the MQTT Broker and transmit such command to the front of the Smart plug and display when receiving the plug details registered in the database. The system will use the obtained data to search in the database used to store the statistics of the electrical usage of the plug to display in the specified format. In addition, applying the MySQL database with MQTT Protocol also help increase the speed of Smart Plug control, due to the MySQL database will recognize some data causing the reduction of messages size sent through the MQTT Protocol. In general practice of MQTT data transmission, we prefer to transmit the String data in Json format, as shown in Table 3.1.

**Table 3.1 Example of data formats in MQTT**

Format	JSON	MySQL
Format of message	<pre>{   " results ":[     {"Plug name":"Plug01"},     {"Plug id":"73269"},     {"Data":"188.8"},     {"Command":"true"}   ] }</pre>	On, Off, 5000
Size of message (Byte)	118	4

Referring to Table 3.1, it can be seen that the messages transmitted through MQTT in Json format contains up to 118 bytes, unlike the system using MySQL to join, it contains not over 4 bytes. This is because the database reduces the size of unnecessary messages, and leaving only On/Off command or electricity consumption values.

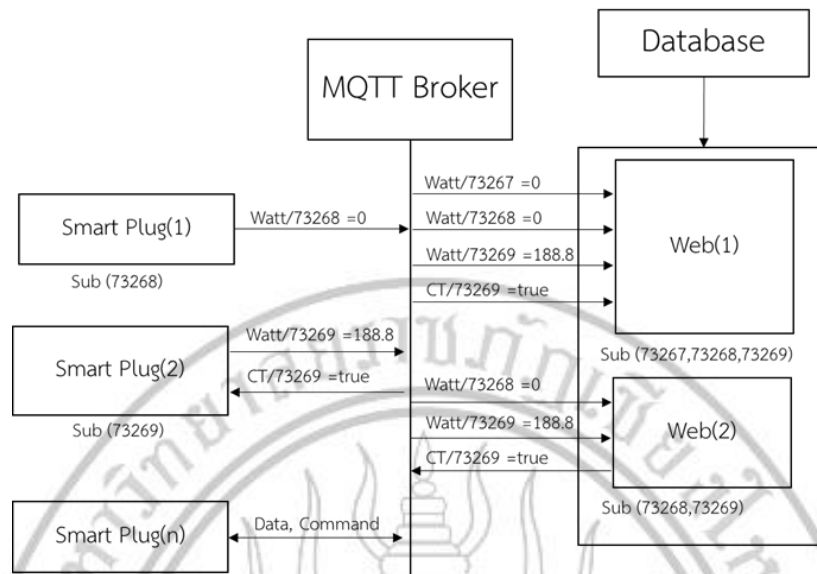
## 4. MQTT Broker for Smart plug



**Figure 3.9** Process 4 of level 1 diagram

Referring to Figure 3.9, MQTT Broker is a medium to transmit data to the device connected to MQTT Protocol. The working principle of Broker is to check if any plugs subscribe to request data from Broker. Each Smart plug connecting to the Internet will automatically subscribe topic with its own Plug ID, as an example of Figure 3.10.

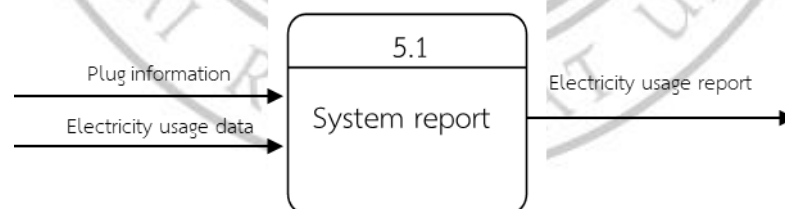




**Figure 3.10** Example of data transmission of smart plug

Referring to Figure 3.10, it can be seen that Smart plug subscribe and publish with its own Topic. It won't be able to transmit data to other Topics. It is different from the web application which can subscribe and publish for over 1 topic, causing the web can control other connected plugs when the user enter correct plug ID. Server-side script is an automatic program running on the server. It gets the data communicated in MQTT Protocol as well as records various data into the database. In case of any incident occurs according to the specified condition, the program will send alerts to user via LINE Application.

5. Report System



**Figure 3.11** Process 5 of Level 1 diagram

Referring to Figure 3.11, Report System is a system displaying the data of electricity consumption of user to the system administrator. The system will use the data from the database to summarize the results and display to the system administrator.

### **A process description of designing the working principle for online systems**

A process description is an additional DFD explanation table. It is the required standard for using DFD every time (Zhang, Liu, Xiong, & Dong, 2018). The process description table allows readers with DFD knowledge can understand the task faster. This is because the process description is structured and clearly defined. A process description of designing the working principle for online systems as detailed in Section 2 can be described in the following table.

**Table 3.2 Process description 1.0**

Process Description	
System	Member Management System
DFD Number	1.0
Process name	Membership system
Input data flows	Register information, Information Edit Profile
Output data flows	Personal information, Membership information reports for system administrators

**Table 3.2 (Cont.)**

Data stored used	Member database
Description	The membership system is divided into 3 functions: 1. Register. The registration system will accept subscription information and insert information to the member database. 2. Edit information. The data editing system will import the data to edit the database. 3. Report member information. The member system will search all users in the database and display results.

**Table 3.3 Process description 2.0**

Process Description	
System	Plugs management system
DFD Number	2.0
Process name	Plugs management
Input data flows	User information, Plug information
Output data flows	Plug information
Data stored used	Member database, Plug database
Description	The member system is divided into 3 functions: 1. Add 2. Delete 3. Edit. The system will accept data from users or system administrators. And then bring the information to manage the plug-in database.

**Table 3.4 Process description 3.0**

Process Description	
System	Control and display system
DFD Number	3.0
Process name	Control and display
Input data flows	User information, Control commands, Plug data
Output data flows	Electricity usage data
Data stored used	Plug-in database, Electricity usage statistics database
Description	The member system is divided into 2 functions: 1. Plug control page the system will accept the user control information and then forward the command to the MQTT Broker. 2. Display electricity usage data. The system will search the user's plug information and then bring the plug data to search in the electricity usage statistics database and then display the statistics.

**Table 3.5 Description of process 4.0**

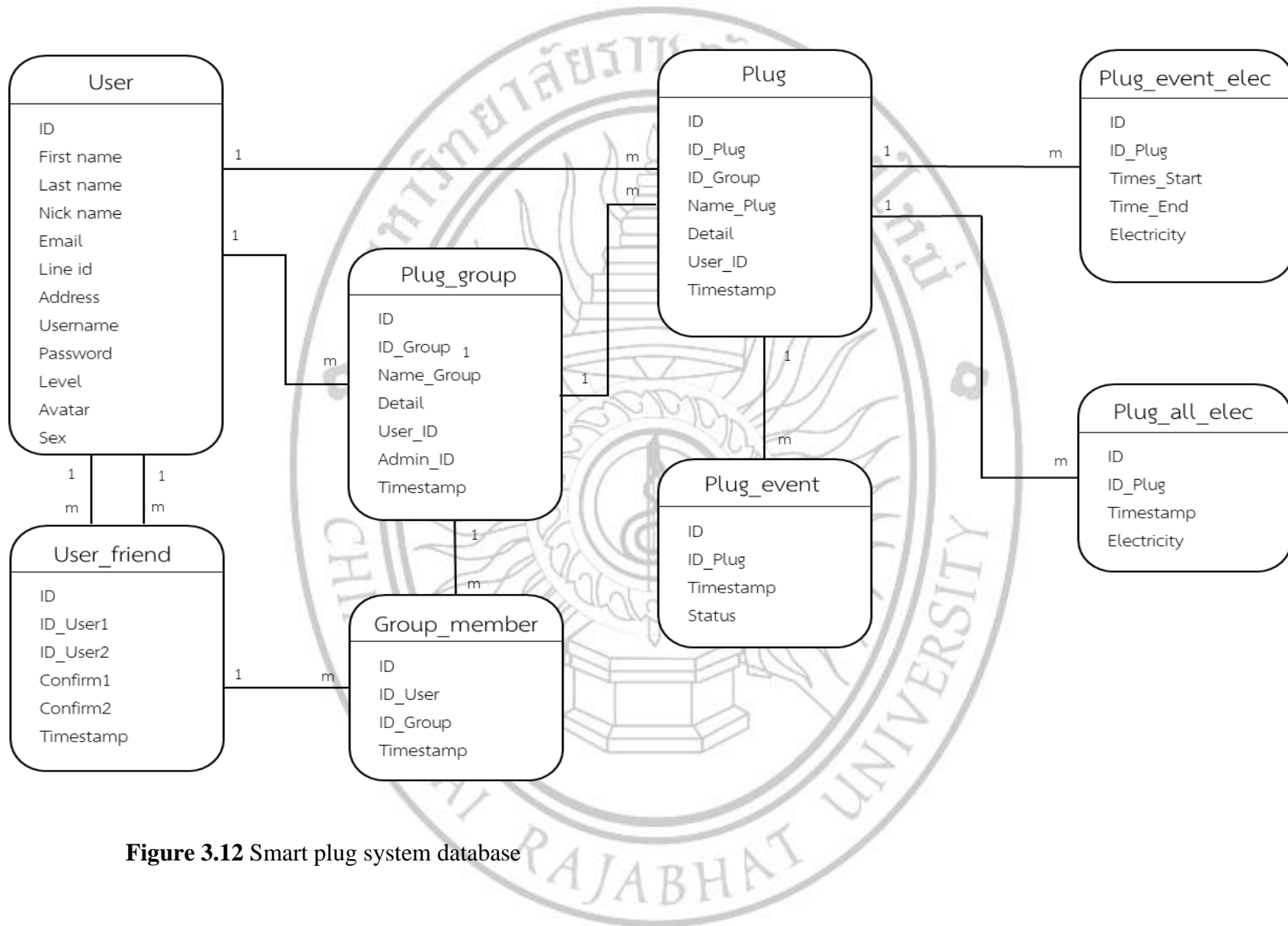
Process Description	
System	MQTT Broker for Smart plug
DFD Number	4.0
Process name	MQTT Broker
Input data flows	Plug ID, Control commands
Output data flows	Plug ID, Control commands, Electricity usage data
Data stored used	-
Description	MQTT Broker is a system to send commands and information between users and Smart plug Server-side script is an automated system that records data in the electricity usage statistics database

**Table 3.6 Process description 5.0**

Process Description	
System	Report system
DFD Number	5.0
Process name	Report system
Input data flows	Electricity usage data, Plug data
Output data flows	Electricity usage report
Data stored used	Electricity usage statistics database
Description	Report system is a system that brings all electricity usage statistics in the database to summarize and display to the system administrator

## Database design

Database design refers to the design of data structure and data relationship used to store data of Smart Plug systems. The database is designed to store member information, plug data, plug groups, electricity consumption rate, etc. Explaining the details of database systems is difficult because the database system consists of complex details and links. To design the database, the researcher implements ER Diagram and Data Dictionary to explain the database system universally and easy to understand. The ER Diagram is a simulation chart describing the database structure and data relationship. It consists of Entity (An object or thing that we are interested in that system), Attribute (The properties of the objects that we are interested in.), Relationship (Relationship between entities) and Data Dictionary (Table showing details of various data in the database, including Relation Name, Attribute, Aliases Name, Data Description, Attribute Domain, etc.) These components allow us to find the requisite details conveniently (Liu, Zeng, Zhang, & Zou, 2018; Villa, Moreno, & Guzmán, 2018). To design the database for DC Smart Plug, there are details of ER Diagram and Data Dictionary as presented by following figure and table.



**Figure 3.12** Smart plug system database

**Table 3.7 User information (User)**

Order	Field Name	Description	Type	Format	Data Range	Ignore	Key	Reference Table
1	ID	User ID	Int(11)	1-999...	0-999999999999	Null	PK	
2	First name	First name	Char(30)	xxx...		None		
3	Last name	Last name	Char(30)	xxx...		None		
4	Nick name	Nick name	Char(20)	xxx...		None		
5	Email	Email	Text	xxx...		None		
6	Line id	Line account	Text	xxx...		None		
7	Address	Address	Text	xxx...		Null		
8	Username	Username	Char(20)	xxx...		None	Unique	
9	Password	Password	Char(20)	xxx...		None		
10	Level	User level	Char(10)	xxx...		None		
11	Avatar	User image name	Char(25)	xxx...		None		
12	gender	gender	Char(10)	xxx...		None		

**Table 3.8 Group members (Group\_member)**

Order	Field Name	Description	Type	Format	Data Range	Ignore	Key	Reference Table
1	ID	Reference ID	Int(11)	1-999...	0-999999999999	Null	PK	
2	ID_User	User reference ID	Int(11)	1-999...	0-999999999999	None	FK	Table 3.8
3	ID_Group	Group reference ID	Char(10)	xxx...		None	FK	Table 3.11
4	Timestamp	Recorded event time	Timestamp	datetime		Null		

**Table 3.9 Friend information (User\_friend)**

Order	Field Name	Description	Type	Format	Data Range	Ignore	Key	Reference Table
1	ID	Reference ID	Int(11)	1-999...	0-9999999999	Null	PK	
2	ID_User1	User reference ID	Int(11)	1-999...	0-9999999999	None	FK	Table 3.8
3	ID_User2	Friend's reference ID	Int(11)	1-999...	0-9999999999	None	FK	Table 3.8
4	Confirm1	User status confirmation	Int(1)	0,1	0-1	None		
5	Confirm2	User status sequence 2	Int(1)	0,1	0-1	None		
6	Timestamp	Recorded event time	Timestamp	datetime		Null		



**Table 3.10 Plug groups (Plug\_group)**

Order	Field Name	Description	Type	Format	Data Range	Ignore	Key	Reference Table
1	ID	Reference ID	Int(11)	1-999...	0-999999999	Null	PK	
2	ID_Group	Group reference ID	Char(10)	xxx...		None		
3	Name_Group	Group name	Char(20)	xxx...		None		
4	Detail	Group detail	Text			None		
5	User_ID	User reference ID	Int(11)	1-999...		None	FK	Table 3.8
6	Admin_ID	Admin reference ID	Text	xxx...		None	FK	Table 3.8
7	Timestamp	Recorded event time	Timestamp	datetime		Null		

**Table 3.11 Total electricity consumption statistics (Plug\_all\_elec)**

Order	Field Name	Description	Type	Format	Data Range	Ignore	Key	Reference Table
1	ID	Reference ID	Int(11)	1-999...	0-999999999	Null	PK	
2	ID_Plug	Plug reference ID	Char(10)	xxx...		None	FK	Table 3.13
3	Timestamp	Recorded event time	Timestamp	datetime		Null		
4	Electricity	Electricity consumption	Double	999.99		None		

**Table 3.12 Plug information (Plug)**

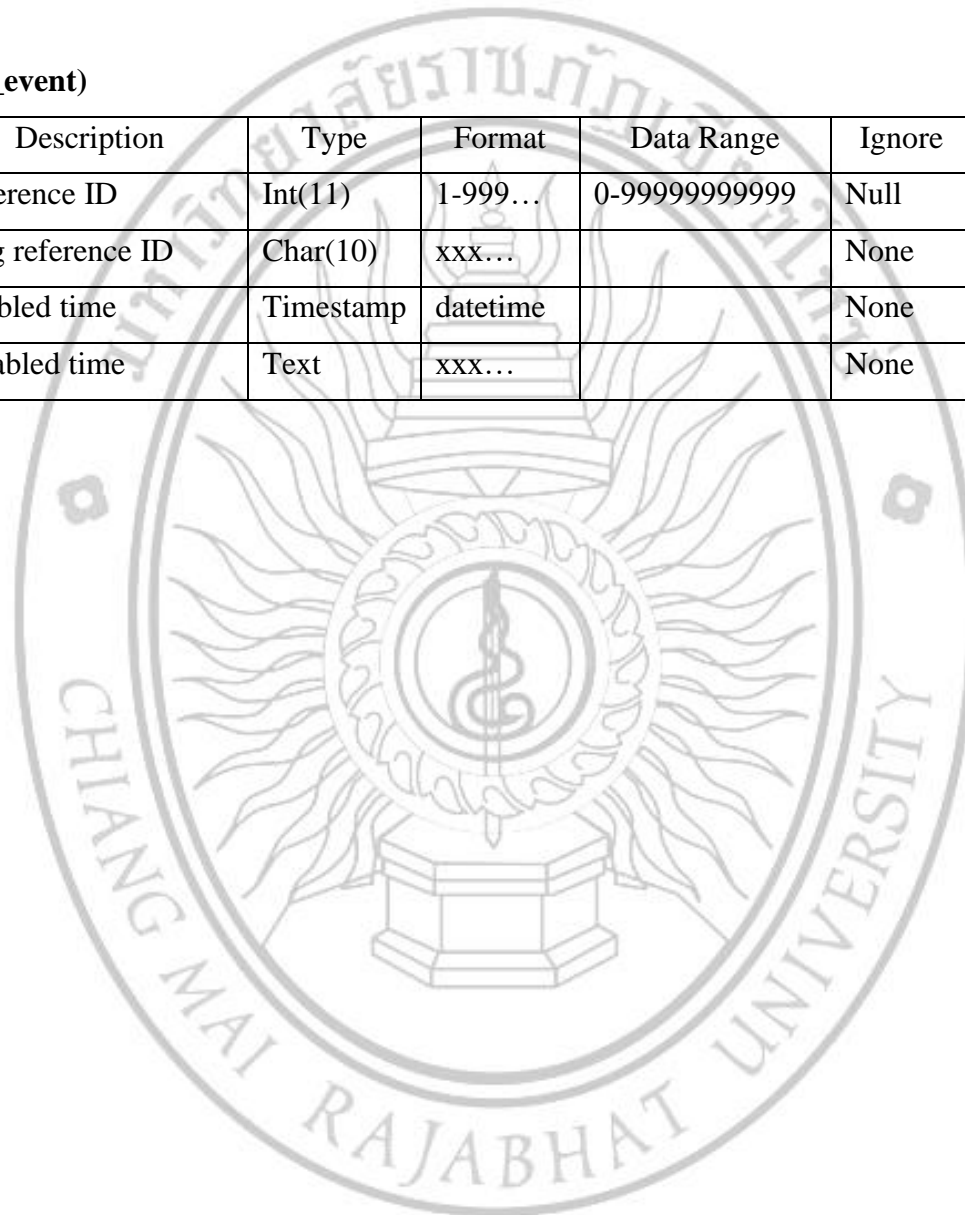
Order	Field Name	Description	Type	Format	Data Range	Ignore	Key	Reference Table
1	ID	Reference ID	Int(11)	1-999...	0-99999999999	Null	PK	
2	ID_Plug	Plug reference ID	Char(10)	xxx...		None		
3	ID_Group	Group reference ID	Char(10)	xxx...		None	FK	Table 3.11
4	Name_Plug	Name of plug	Char(20)	xxx...		None		
5	Detail	Plug detail	Text			None		
6	User_ID	User reference ID	Int(11)	1-999...	0-99999999999	None	FK	Table 3.8
7	Timestamp	Recorded event time	Timestamp	datetime		Null		

**Table 3.13 Electricity usage statistics per time (Plug\_event\_elec)**

Order	Field Name	Description	Type	Format	Data Range	Ignore	Key	Reference Table
1	ID	Reference ID	Int(11)	1-999...	0-99999999999	Null	PK	
2	ID_Plug	Plug reference ID	Char(10)	xxx...		None	FK	Table 3.13
3	Times_Start	Enabled time	Timestamp	datetime		None		
4	Time_End	Disabled time	Timestamp	datetime		None		
5	Electricity	Electricity consumption	Double	999.99		None		

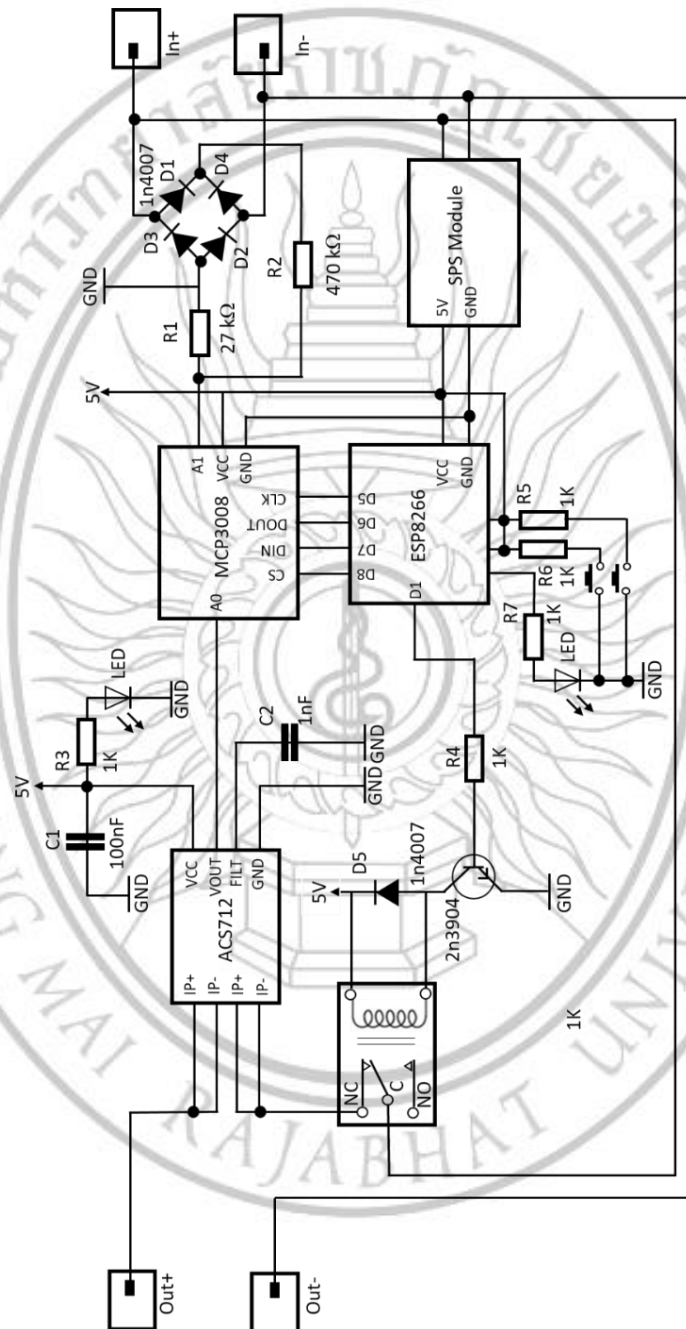
**Table 3.14 Events log. (Plug\_event)**

Order	Field Name	Description	Type	Format	Data Range	Ignore	Key	Reference Table
1	ID	Reference ID	Int(11)	1-999...	0-999999999999	Null	PK	
2	ID_Plug	Plug reference ID	Char(10)	xxx...		None	FK	Table 3.13
3	Times_Start	Enabled time	Timestamp	datetime		None		
4	Status	Disabled time	Text	xxx...		None		



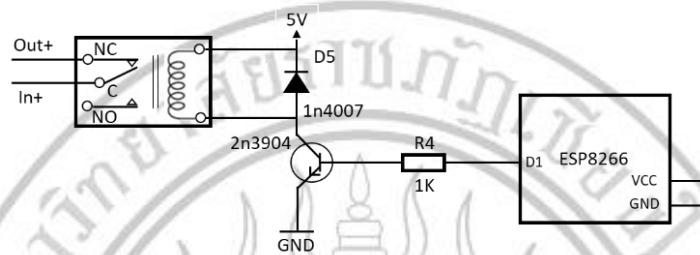
## Hardware development system design

Hardware development system design is required to combine electronic components together on the electronic circuit board in order to work as needed. The development design of Smart Plug system includes the details of connected devices as shown in Figure 3.14.



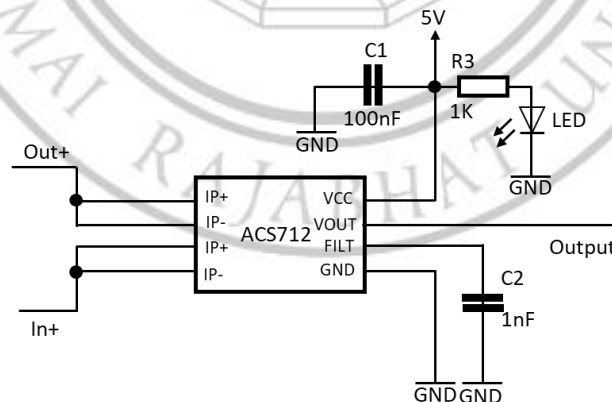
**Figure 3.13** Smart plug electrical circuit

Figure 3.13 is an electronic circuit diagram with the ability to control the electrical energy flowing through. The system will apply the connected electric power to make the electronic system work. After the electronic circuit is working, the system will check the energy received together with control the electricity according to the commanded program. There are 4 main components of the circuit as following details.



**Figure 3.14** Electrical circuit cutting

Figure 3.14 is an electric circuit to receive command from the MCU to control turn-on / turn-off electric appliances. In regard to the working principle of this circuit, MCU will supply 0-5 VDC voltage through the voltage converter circuit according to the figure. When the MCU supply voltage for over 3 VDC, the electric magnet of Relay will attract the contacts to change the condition. Therefore allowing the power supply system to supply electricity to the devices connected. However, if the MCU supply voltage for less than 3 VDC, the Relay will not have enough power to create an electromagnetic field, then result in the contacts return to its original position. At this algorithm, electrical appliances connected to the plug will not receive electricity.

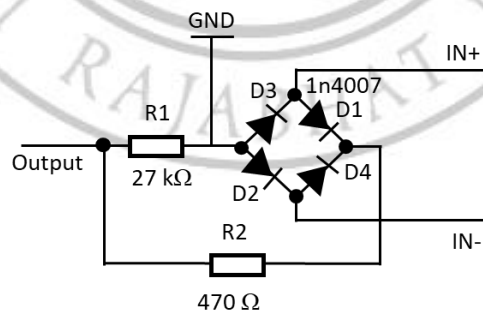


**Figure 3.15** Current sensor circuit

Figure 3.15 is the current sensor circuit. It acts to measure the electricity consumption. The working principle is to use IC numbered ACS712 IC to measure the current flowing through. The positive electrode will flow through the leg number 1,2 (IP+) and flow out in the leg number 3,4 (IP-), causing Hall phenomenon or Hall effect, then resulting in the output of 0-5 VDC voltage. In this algorithm, we can take the MCU to read the output directly, then apply mathematical equations to convert the obtained data into the operating current electricity. Nevertheless, there is interference in the output, causing the actual current to be inaccurate. Regarding to Figure 3.16, there is a circuit for reducing noise by using capacitors to help reduce interference. The researchers connected C1 with a 100uF value to put across between the VCC and GND pins as Bypass Capacitors, noise filters coming from the distributing source. Later, connecting C2 with 1.0 nF value at the filter pin to determine the bandwidth of the IC. Filter legs are in line with the standard value which the manufacturer set to have a bandwidth of not more than 90 kHz. We can find Bandwidth from Equation 1 as follows.

$$F = \frac{1}{(2\pi RC)} = \frac{1}{(11k\Omega \times (1nF + CF))} \quad (1)$$

Equation 1 is used for finding bandwidth. F is defined as the frequency being reduced. CF is the C2 value connected to the filter. From the above equation, when setting Bandwidth as a constant value, it results in finding the requisite C2 value.



**Figure 3.16** Voltage sensor cutting

Figure 3.16 is a voltage sensor circuit that serves to measure voltage applying Ohm's Law. The working principle uses R1 and R2 resistors to serialize across the power supply. Regarding the Ohm's law, the voltage from the power supply is divided between the two resistances, causing the output voltage to be increased and decreased according to the obtained input. We can call this phenomenon that the voltage drop or R-Divider (Nagar & Paul, 2018; Šuch, Klimo, Kemp, & Škvarek, 2018) At this algorithm, we can use the MCU to read the measured voltage in order to apply the obtained value to the Smart plug. To make the MCU read the value of the voltage drop, the output must be at 0-5 VDC. Therefore, the R1 and R2 resistors must be configured to have an output voltage not exceeding 5VDC. The calculation method of the voltage drop will be done by the following equation.

$$V_{out} = \frac{V_s \times R_2}{R_1 + R_2} \quad (2)$$

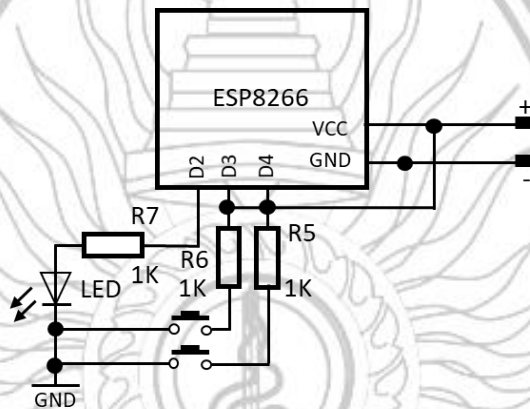
Equation 2 is used for representing the constant value of Voltage Input, R1 and R2 to calculate the voltage drop. From this equation, we can reverse the equation to find the appropriate value of R1 and R2, referring to the voltage output with not exceeding 0-5 V which concerns the details as presented in the following Equation 3.

$$R_1 = \frac{V_s \times R_2}{V_{out}} - R_2 \quad (3)$$

Regarding equation 3, the R1 value can be calculated by determining the constant voltage input, output and R2 as following Equation 4.

$$R1 = \frac{300 \times 470}{5} - 470 \quad (4)$$

In equation 4, we define  $V_s$  as equal to 300 for determining the sensor to support electricity at a maximum current of 300 V. The  $V_{out}$  is set to have the Voltage Output equal to 5 and  $R_2$  with the value of 470, because it is a resistance available in general. When replacing the value, we obtain the answer of 27730 Ohm. We can apply 27 kOhm resistors. From this equation, we obtain the values used for  $R_1$  and  $R_2$  resistors to join in parallel with the power supply and use the output.



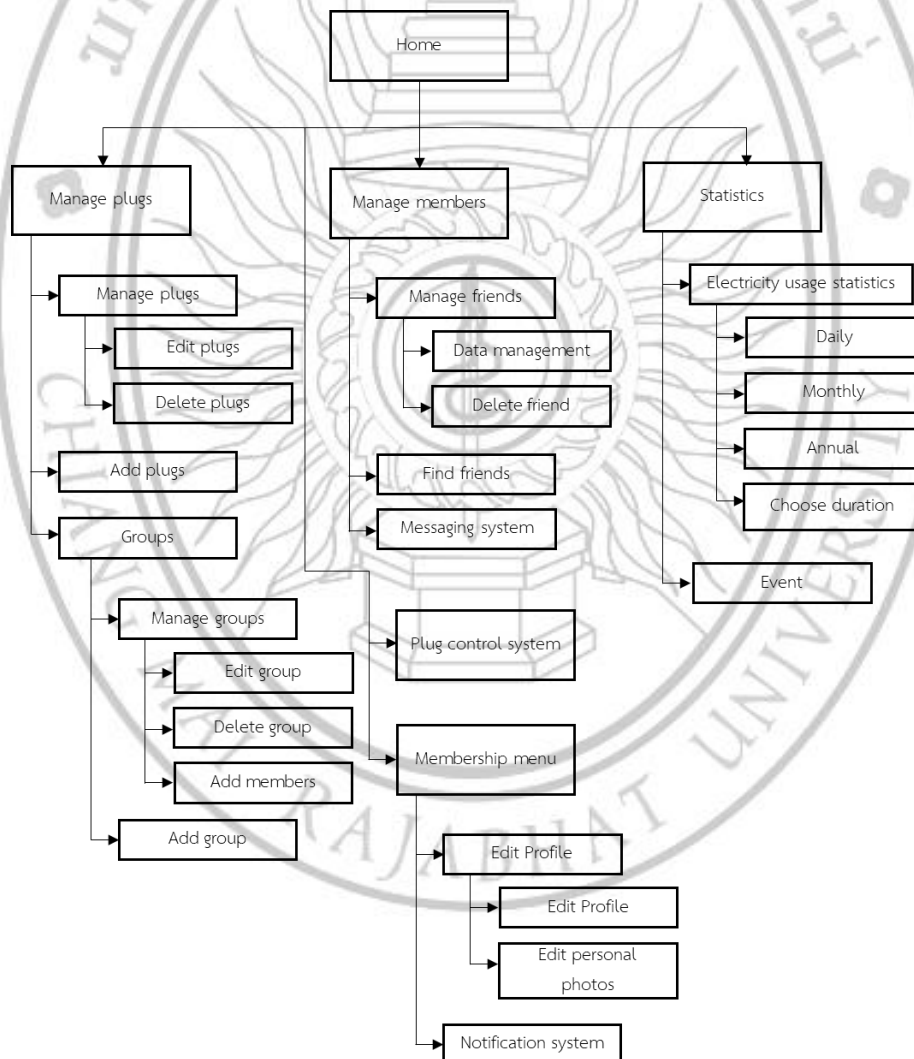
**Figure 3.17** Button and status light

Figure 3.17 is a circuit for receiving values from 2 push buttons and displaying results via LED status lights. The working principle is to apply the 1 k resistor to connect with  $V_{cc}$  (+5V) so that keep the pressure constant in the HIGH or 1 status all the time. When pressing the switch, the electricity will flow immediately into the ground, resulting in the status of LOW or 0 Logic. It enables the MCU to verify that the push button is pressed. The working circuit of the status light is that the MCU supply electric power to D2 leg with HIGH status, which allows the LED bright.



### Display screen design

The display screen design is the design of the style and method of displaying data on the website. The website is a medium that allows users to connect with the Smart plug. The display screen design is therefore an important part of the system development. In addition, the display screen design helps to develop a good management style. The development of complex systems will be done easier. The design identifies the specific position of the functions displayed on the website, enabling developers to know which points needed to be developed. The developer created the display format and control system through the Web application. There is a site map as shown in Figure 3.18.

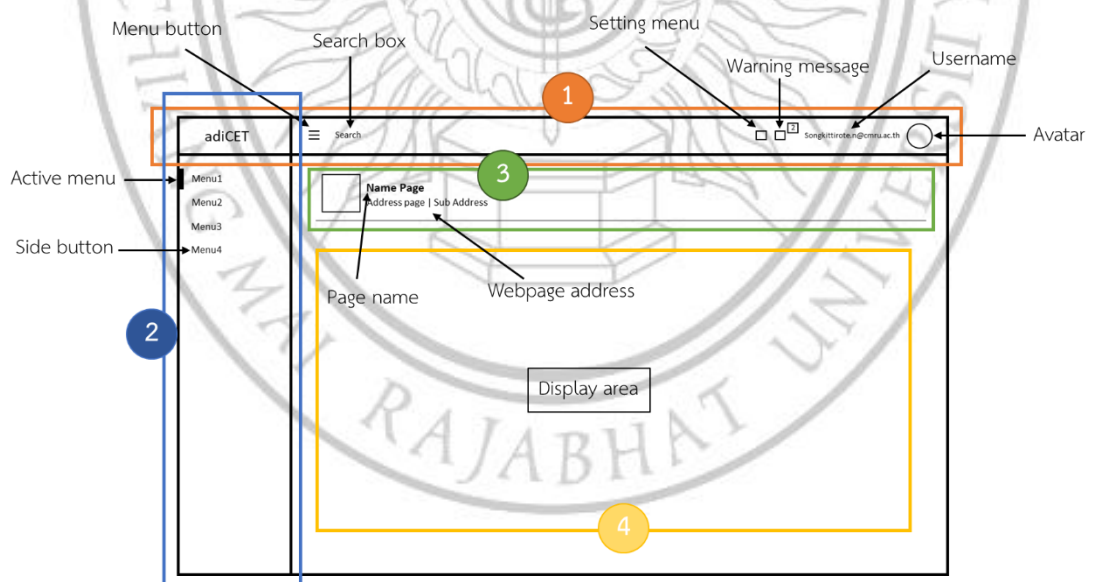


**Figure 3.18** Websites structure

Figure 3.18 is a diagram showing the structure of websites concerning different functions. It consists of 5 main functions, namely Plug Management System, Friend Management System, Statistics Display System, Plug Control System and Member Management System. Regarding the design of display screen, we must design the website window to be able to support all functions, to have a display style without complexity, to have the same look so as not to cause confusion. It looks good, simple and effective. The design of the display screen can be divided into 5 parts as follows:

### Web layout design

Web layout design is the basic display system design used as the layout of the display on every webpage. Such design will help the web system look more structured with a clear and standard format. It enables users to understand the web system immediately even accessing the web for the first time. The proper window design must be clean and without too complicated operating parts. In addition to make the web system look good, also not look boring when used every day. In the design of the web window, there are 4 parts of its components, including 1) Top navbar, 2) Sidebar Menu, 3) Section showing the name and address of the webpage and 4) Web content display. Such components can be described in Figure 3.20.



**Figure 3.19** Web layout

Referring to Figure 3.19, the web layout details can be explained by the following numbers:

1. Top navbar is a section designed for displaying simply information for users. It operates at the top of the display screen. The Top navbar helps facilitate web users, because the menu design is simple, reduce the complexity of the program by using the image symbol instead of messages. The details of Top navbar are as following topics.

1.1 Searching box is a box for searching the website or other information required.

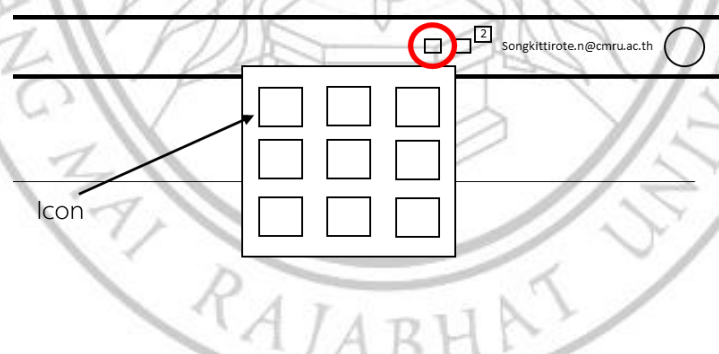
1.2 Quick menu is a menu for displaying link to setting function or link to another web page.

1.3 Alert Message is a menu for system notifications or messages from other members in the system.

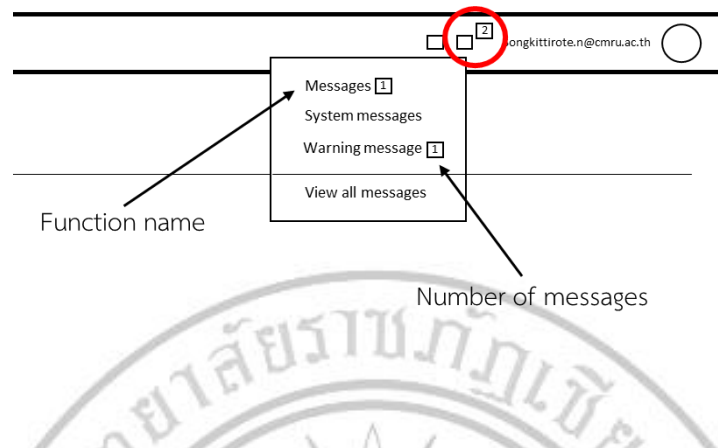
1.4 Full screen mode is a menu that allows websites to display information in full screen.

1.5 Avatar menu shows the user's photo and personal settings menu.

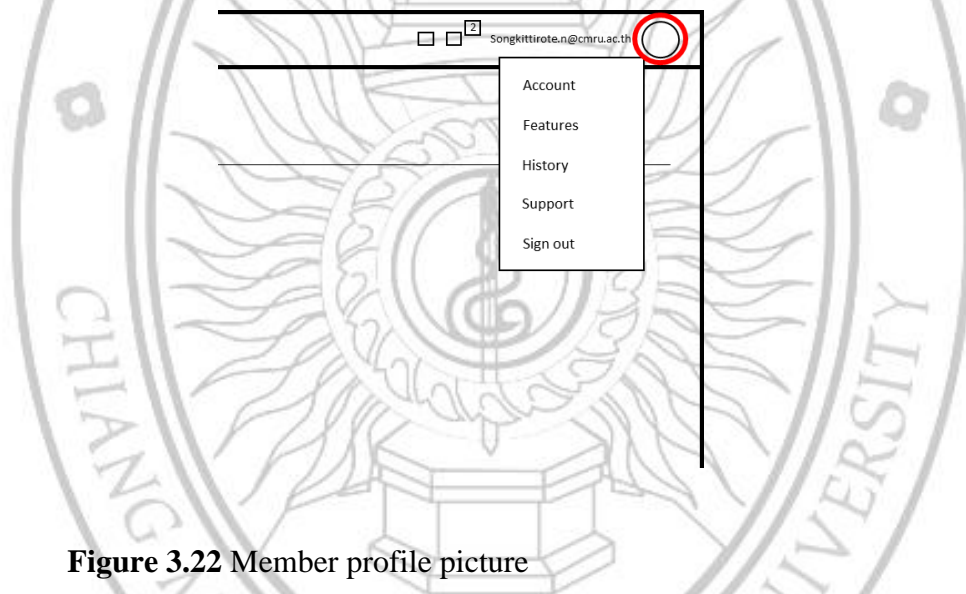
The above section details about the functionality of the header menu. Each function will show more details when users click on that menu. After the menu is clicked, the system will display a popup with details as shown in Figure 3.20-3.22.



**Figure 3.20** Quick menu

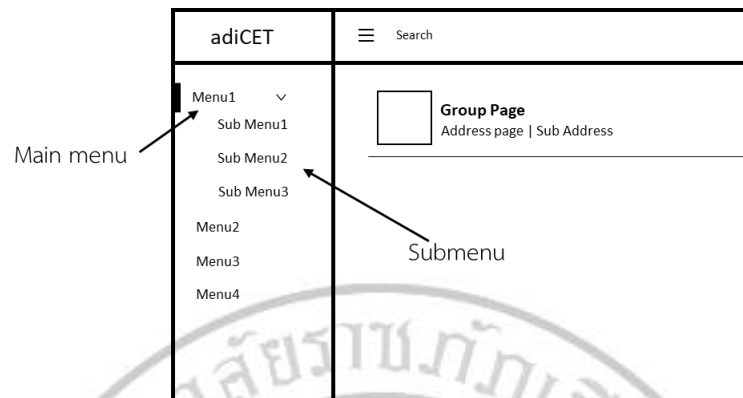


**Figure 3.21** Warning message



**Figure 3.22** Member profile picture

2. Sidebar Menu is a menu for displaying the main function keys of the system displayed on the left side of the display screen. In this menu, it is designed to be simple, showing only the icons and messages. However, it will hide more details in the Popup displayed only when the user clicks the button. Inside the submenus, a link will show the details to connect to other pages. The appearance of the side menu display contains the details as shown in Figure 3.23.



**Figure 3.23** Sidebar menu

3. Section showing the name and address of the webpage is the section showing the details of the website. This function will help users know which function is currently used. It exists in which category and in which position of the Smart Plug system. The appearance of the display has details as shown in Figure 3.24.



**Figure 3.24** Section name

4. Web content display is the area designed to display data within the specified location only, sized at 1024 x 768 px. The display characteristics are detailed in Figure 3.25.



**Figure 3.25** Web content display

### **Display Screen Design for plug control and plug management system**

Display Screen Design for plug control and plug management system is the design of the display part relating to the control and management of the plug. The designing of working windows can be divided into the following topics.

#### 1. Plug management window

Plug management window is a window for managing (adding, deleting, editing) plug data in the database. In regard to the working principle of the system, users need to add information about the plug to the database so that the system can control the Smart plug system. When the database system gets such information, it will display the control window for the user to control the plug. The window has a visual appearance as shown in Figure 3.26-3.28.

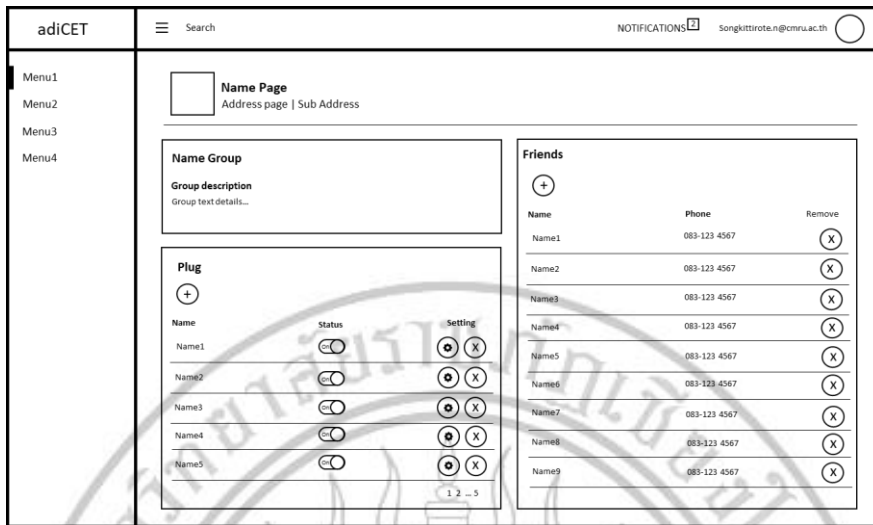


Figure 3.26 Window for show plug data

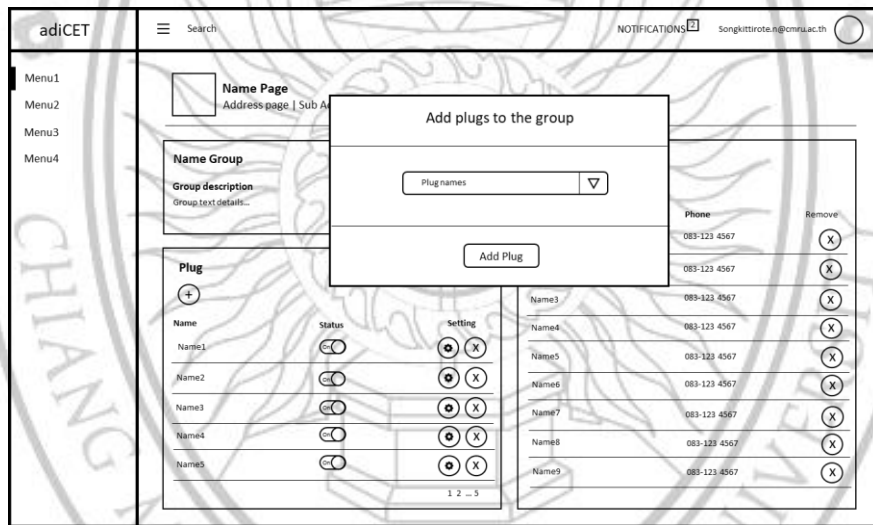


Figure 3.27 Window for add plug to group

The screenshot shows a web application interface for 'adiCET'. At the top, there is a header with the logo 'adiCET', a search bar, and user information including 'NOTIFICATIONS' and an email address 'Songkittirote.n@cmru.ac.th'. On the left side, there is a vertical menu with items 'Menu1', 'Menu2', 'Menu3', and 'Menu4'. The main content area is titled 'Name Page' and includes a sub-header 'Address page | Sub Address'. Below this, there is a form with the instruction 'Please fill in all fields.' and three input fields: 'Title', 'Detail', and 'Plugs ID'. A 'Submit' button is located at the bottom right of the form area.

**Figure 3.28** Window for add plug to database

Figure 3.26 is a window for input the plug-in data. The user must enter the data of plug name, plug details and plug ID to the specified box and click the submit button. The system will add data to the database, along with sending the page to the plug management page as shown in Figure 3.27. From the picture in this window, it shows the plug data added by user to all databases on this page. The system will display the edit and delete buttons. The user can manage the plug from the push button via the button in the window. If the user wants to edit the data, then the system will go to the edit window as shown in Figure 3.28, which the user can edit the data in this window.

## 2. Group management window

Group management window is a window for managing (adding, deleting, editing) data about groups in the database. The group system is designed to increase the convenience of Smart plug users relating to the plug control system. If there is a case in which many smart plugs are installed in the home and there are many family members in that house who want to control electric appliances. Family members will have to add the plug data to the system again for the need of electric appliances control which cause the difficulties in this process. The group system is therefore designed to solve such defects. Users can create groups and add their plugs to that group while sharing them with family members. It allows members in the group to control the Smart



plug without adding duplicated data into the system. The design of group management window can be shown in Figure 3.29-3.31.

The screenshot shows the 'Add Group' window in the adICET system. The window is titled 'Add Group' and contains a form with the following fields:

- Title:** A text input field.
- Detail:** A larger text input field.
- Submit:** A button at the bottom of the form.

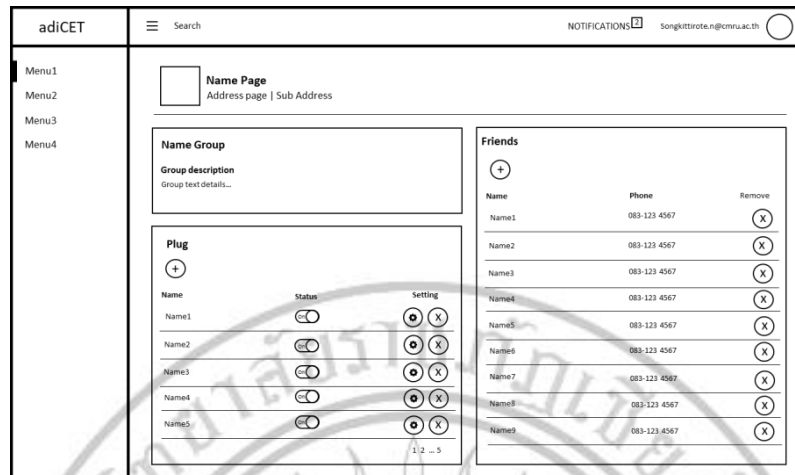
The background shows a list of groups with the following columns: Name, Details, and Remove. The groups are listed as Group1 through Group9. Each group has a 'Detail...' link and a circular icon with a plus sign.

**Figure 3.29** Window for adding group data

The screenshot shows the 'Show group data' window in the adICET system. The window displays a table of groups with the following columns: Name, Details, and Remove. The groups are listed as Group1 through Group9. Each group has a 'Detail...' link and a circular icon with a plus sign.

Name	Details	Remove
Group1	Detail...	
Group2	Detail...	
Group3	Detail...	
Group4	Detail...	
Group5	Detail...	
Group6	Detail...	
Group7	Detail...	
Group8	Detail...	
Group9	Detail...	

**Figure 3.30** Window for Show group data

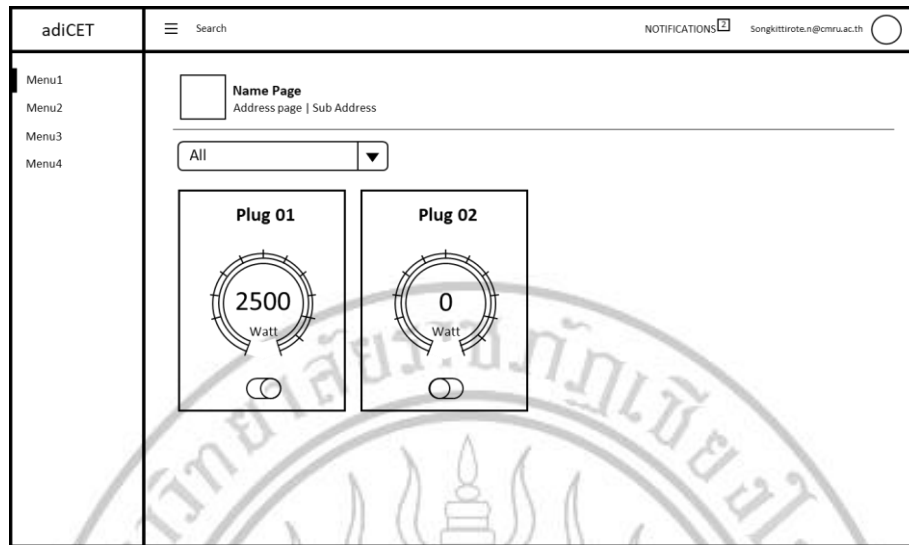


**Figure 3.31** Window for add plugs to the group

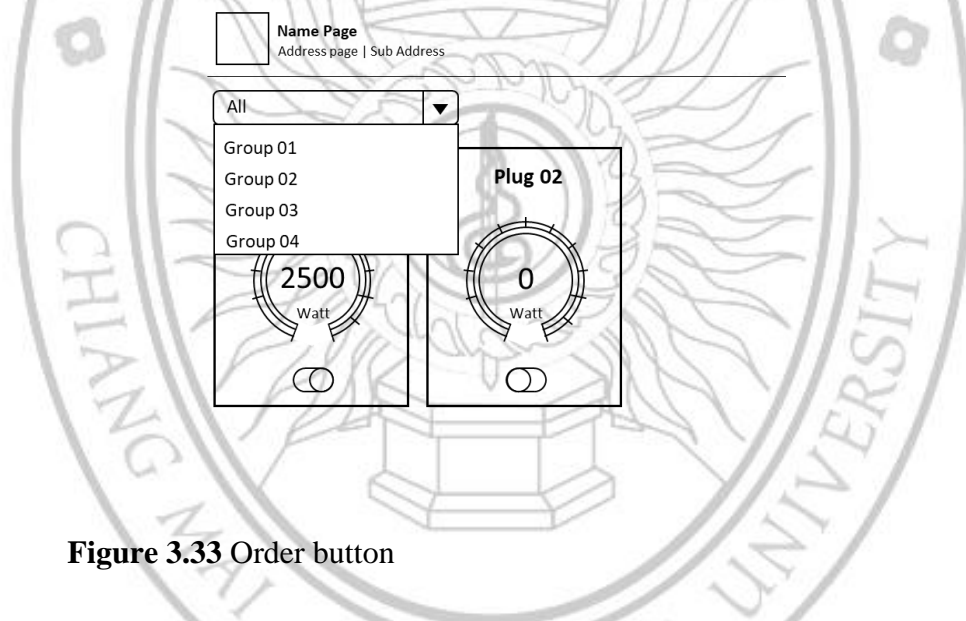
Figure 3.29 is a window for adding group data. In this window, it will display a message box for adding information. The summary details of the group that the user created and the status of the plug in the user-created group. When users add group data, the system displays the group data management window as shown in Figure 3.30. In this window, the system will display all the groups that the user created. Regarding the details about the group, there is a button to manage the plugs in the group as shown in Figure 3.31. In addition, users can add plugs to the group and remove the plug from the group.

### 3. Smart plug control window

This window is a page for controlling Smart plug as well as showing details about the electric consumption rate of the plug. Users can control the Smart plug through the window as shown in Figure 3.32 and also categorize it to be able to control the plug more easily, as shown in Figure 3.33.



**Figure 3.32** Plug control



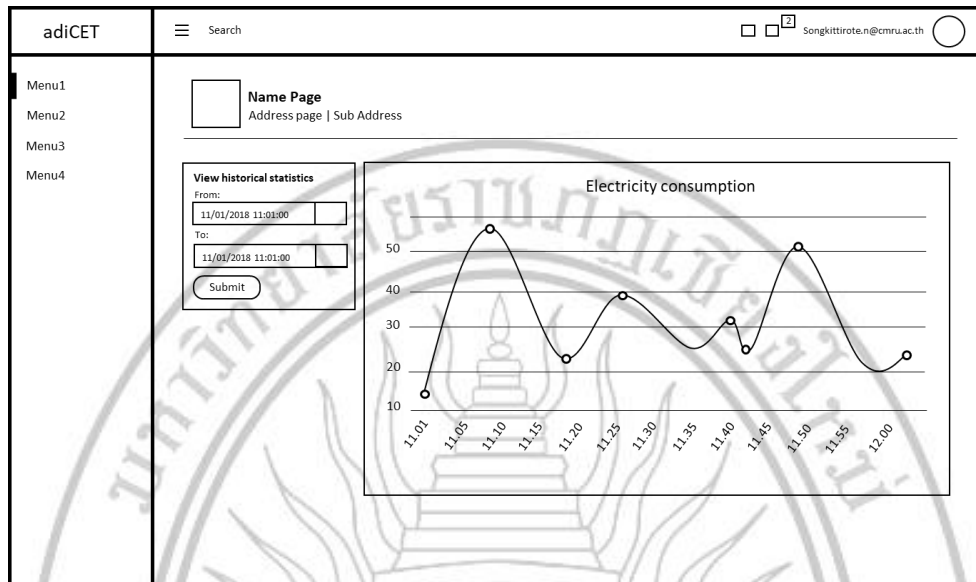
**Figure 3.33** Order button

From Figure 3.33, there is an ‘Order by’ button in the plug-in control window for selecting to display the plug in the group created by users. The system will select to display the plugs in the group only. Furthermore, users can also search for plugs directly from the search box.

#### 4. Design of the electric consumption statistics display screen

The Electric Consumption Statistics Window is a window showing historical electric consumption statistics. This window will display a comparison chart

for the electric consumption rate of each plug. The user can select the date and time from the button specified in Figure 3.34.



**Figure 3.34** Historical electricity usage

Referring to Figure 3.34, when the user selects the date and time of starting and ending points, the system will display the information as specified by the user. Then the window displays the graph of all the user's data plugs in the database.

##### 5. Design of Member display screen

The design of display screen for other member search functions in order to add members to the system. It allows users to share the plug-in data to additional members. The work procedure of this function can be divided into 3 functions, namely 1) Friend search page 2) Success in finding friends page and 3) Friend management page which concern details as shown in Figure 3.35-3.37.

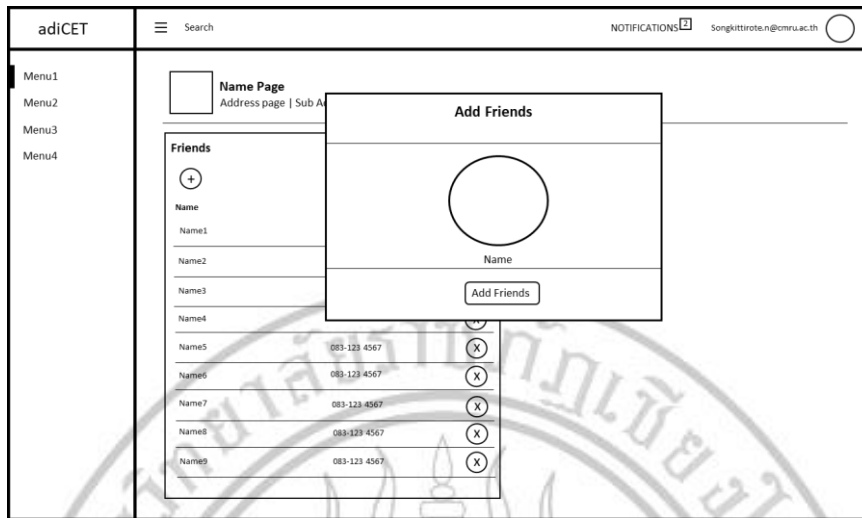


Figure 3.35 Friend search page

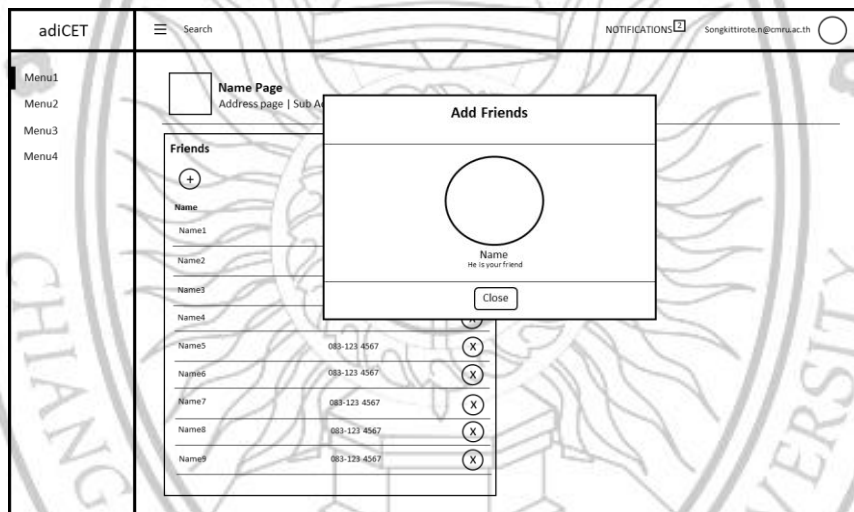
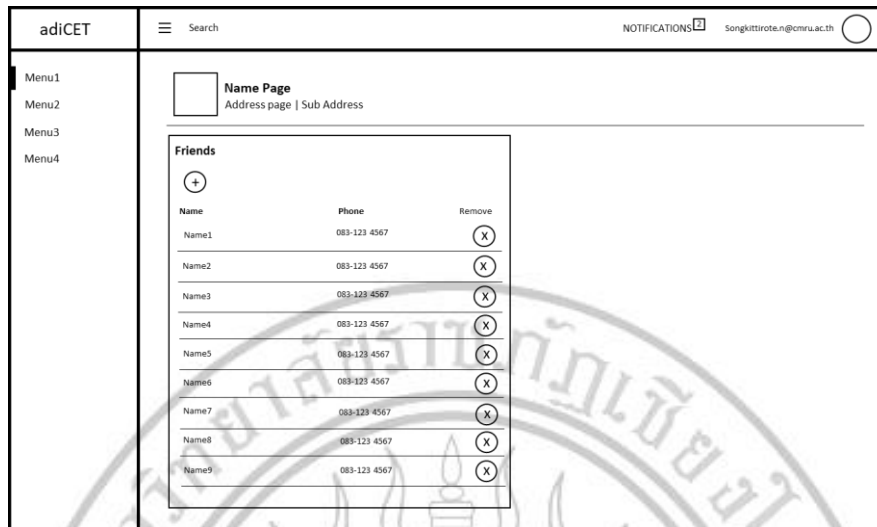


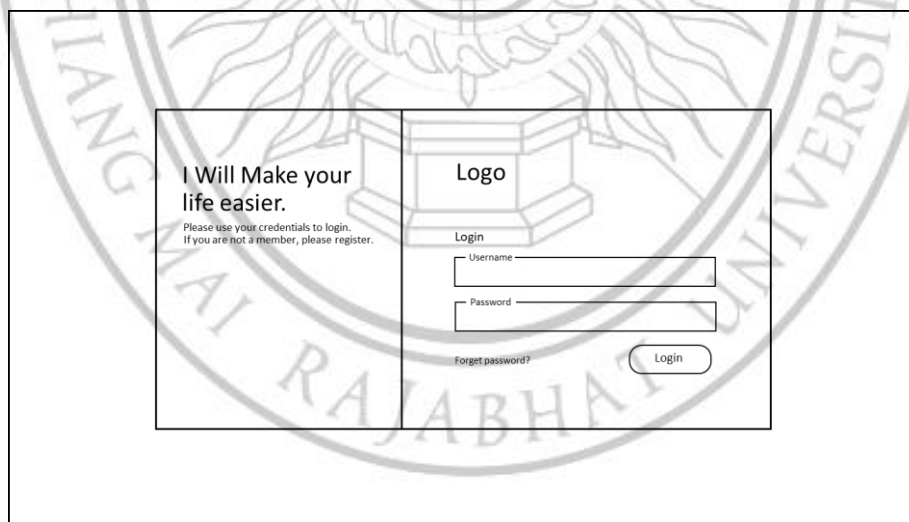
Figure 3.36 Windows success in finding friends page



**Figure 3.37** Friend management page

## 6. Design of other display screens

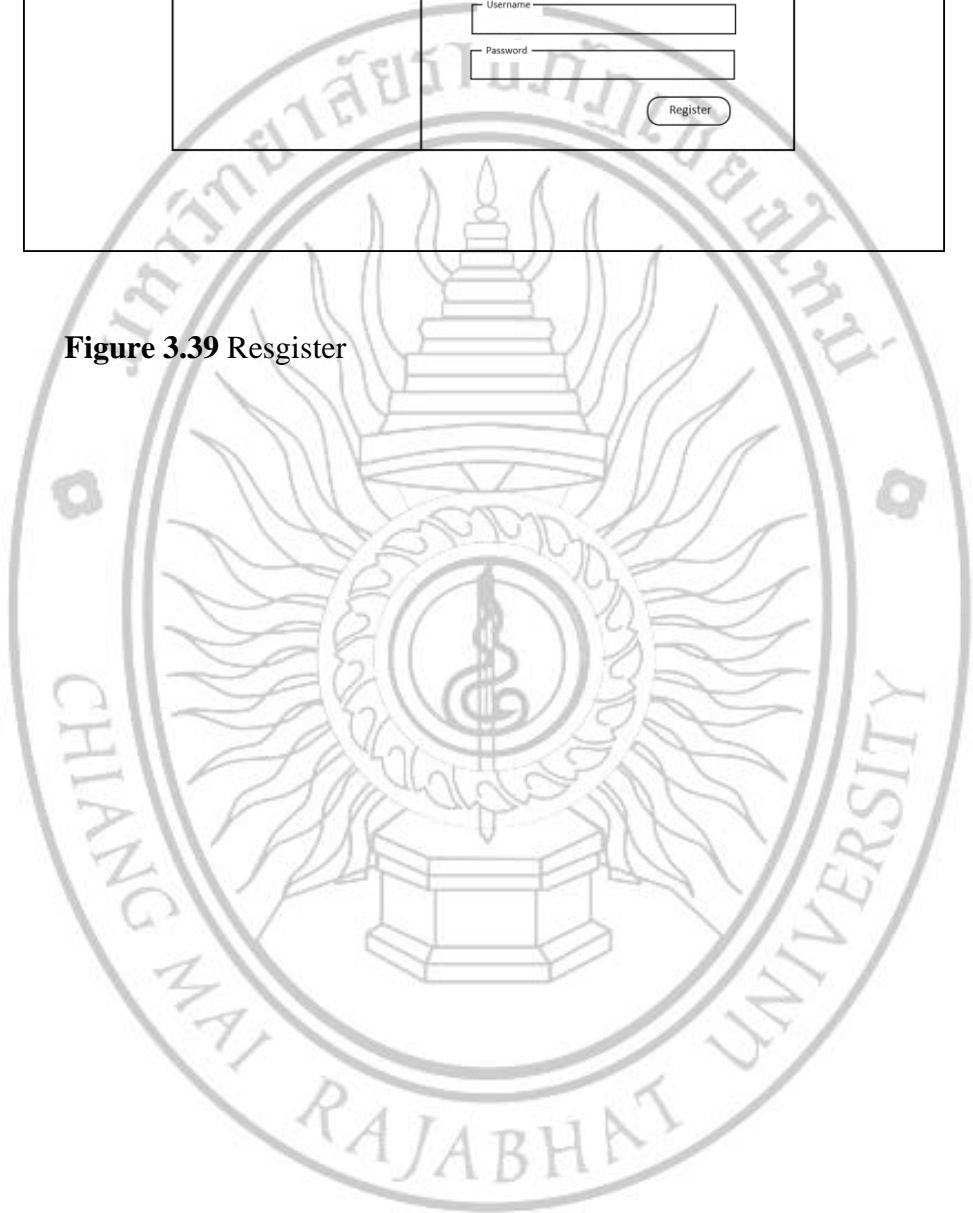
The design of other display screens is a screen design for systems that do not involve the control and display of Smart Plug systems, such as Login, Register and forget password functions. These functions include different formats from other systems to clearly separate the work.



**Figure 3.38** Login

<p><b>I Will Make your life easier.</b> Please use this form to register. If you are a member, please login.</p>	<p><b>Logo</b></p> <p>Register</p> <p>Name <input type="text"/></p> <p>Username <input type="text"/></p> <p>Password <input type="password"/></p> <p><input type="button" value="Register"/></p>
--	--

**Figure 3.39** Resgister



## CHAPTER 4

### RESULTS AND DISCUSSIONS

The development of high-efficiency smart plug for direct current electricity consists of the development about control method, communication modes, Software database and Hardware. The result details of the system development and testing can be explained by the following topics:

#### **Hardware design and development**

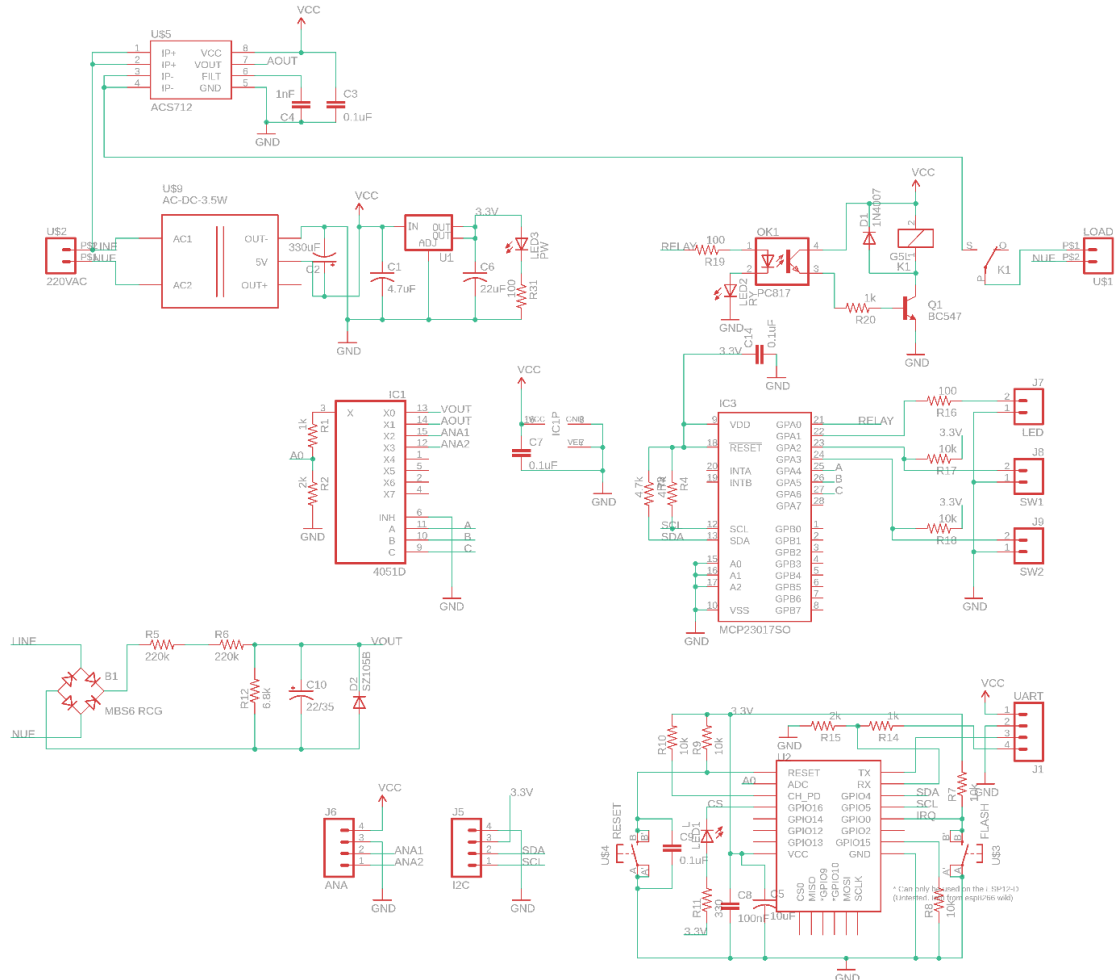
The design and development of hardware system to be used as a device for controlling electric appliances consists of an electronic circuit design to determine the connection pattern of the electronic chipset with different working features. When we have a prototype of the electronic circuit, then it is used to produce an electronic circuit board and make an error test. The design results and system errors can be explained as following topics.:

#### **Hardware design and creation**

The design and development of electric circuit is a process of circuit design by computer program to use the design file to produce a real work piece. The circuit design method starts from the design of chipset connection. In the design process, the researcher uses Eagle PCB program to design electric circuit. Eagle PCB is a software for designing Schematic and PCB Routing. It is popular because there are many electric circuit libraries to choose, making it convenient to design electric circuits. To design an electric circuit, we use the Eagle PCB program to design the Schematic Diagram. That diagram is used to indicate the connection of an electric circuit. The Schematic Diagram design will help facilitate the development of the circuit board. Due to the complexity of the electrical circuit design work, if there is an error with the connecting point, it causes the electric circuit to not work or short circuit. Therefore, the design of the

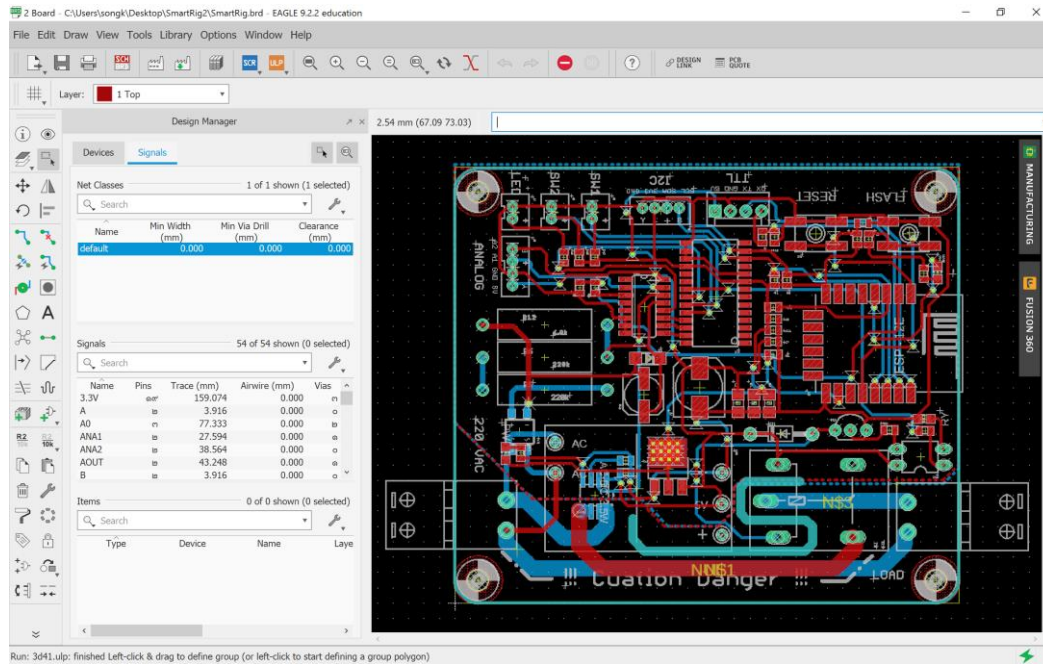


Schematic Diagram is very important for the hardware system development. The details of Schematic Diagram are as shown in Figure 4.1.



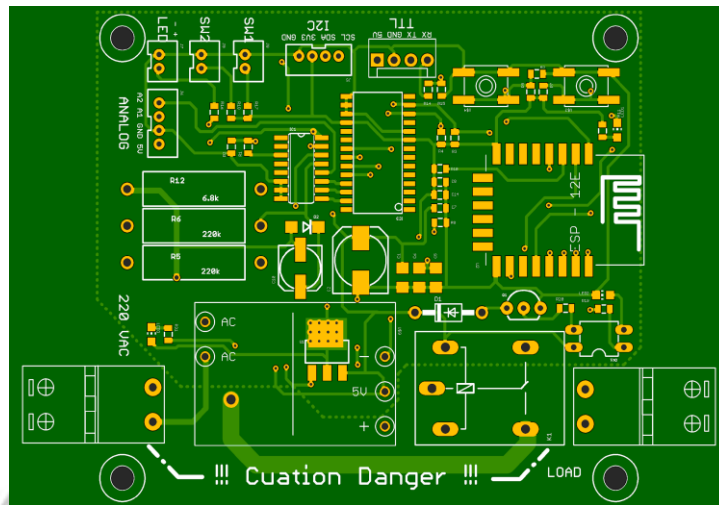
**Figure 4.1** Schematic diagram of smart plug

Figure 4.1 is a schematic diagram describing the details of the connecting chipset. The design of such connections is as prior designed in the topic of the operational methods. The next step after getting schematic diagram is that the researcher designs an electric circuit by determining the connecting line of the chipset according to the schematic diagram. The creation of such lines by the Eagle PCB program will result as shown in Figure 4.2.

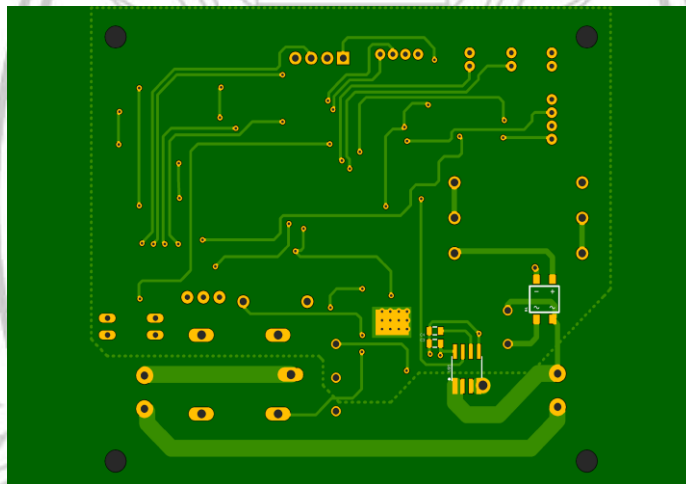


**Figure 4.2** Window for electric circuit design

Figure 4.2 is showing the sample window for electric circuit design by the Eagle PCB program. Regarding to the design process, the PCB is designed to work on both sides, front and back. PCB design to work on both sides will cause the small size of electric circuit. When creating the circuit connecting line as specified, then export the file to produce the actual work piece. From the design and creation by each of electric circuit, thus making a sample of the circuit board model as shown in Figure 4.3 - 4.4.

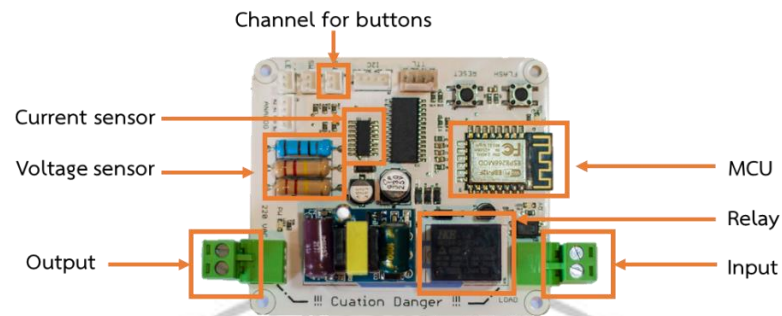


**Figure 4.3** Front circuit board

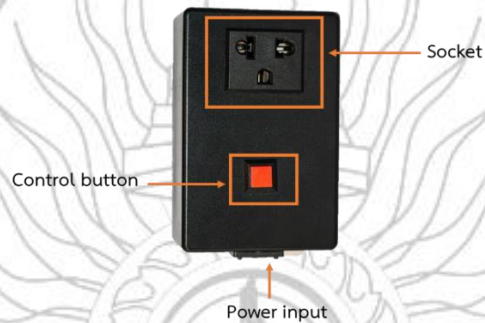


**Figure 4.4** Back circuit board

Figure 4.3 - 4.4 is a circuit for forming the work piece. The next step is to assemble the chipsets together with other components into the PCB board as specified in schematic diagram. Then take the assembled circuit board to install at the box to prevent any danger from electricity. The result of creating the work piece is as specified, including details as shown in Figure 4.5 - 4.6.



**Figure 4.5** Smart plug PCB board



**Figure 4.6** Smart plug box

### **Error test for hardware system**

An error test for hardware system is testing process to check whether the smart plug hardware works as designed or not. An error test will help the researcher recognize the hardware errors, then apply the test results to adjust in order to make the Smart Plug system work correctly, causing the system more stable. Hardware testing process can be divided into 3 parts, namely 1. Functional tests in each function 2. Error test of control system and 3. Accuracy test. The mentioned three parts can be described as follows.

### 1. Hardware function testing

Regarding the process of testing the functionality of the hardware system is a test to check whether each part of the operating hardware can work properly. The experiment method is conducted by testing all the functionality of the hardware system whether it works properly or not. Then record the experiment results which are in accordance with Table 4.1.

**Table 4.1 Hardware function testing**

Function	Test result
1. Get value from button	✓
2. Control Relay	✓
3. On / off LED	✓
4. Supports DC power	✓
5. Supports AC power	✓
6. Measure current	✓
7. Measure voltage	✓
8. Wi-Fi connection	✓
9. Connect to the internet	✓
10. Contact with MQTT Protocol	✓

Table 4.1 present the test results in each function of the hardware system. Each function performs different functions. The test method starts from the testing of basic hardware functions, such as receiving values from the power cut button of the relay circuit, ordering to turn on-off LED lights, receiving input of AC / DC power and electricity and voltage measurement, etc. These functions are the basic function of the hardware system defined from the project objectives. In addition to testing basic functionality, we also test the ability to connect with the communication system, for example, receiving internet signals, Wi-Fi connection and communicating with the server by the MQTT Protocol. Regarding to the experiment results, it was found that all functions are able to work completely as required.

## 2. Error test of control system

Error test of control system is an error test of the smart plug when pressing the control button on the plug if there is any errors. The error test referred on this topic is to test whether the Smart Plug will respond to user's commands in priority order. Since it is the primary security of the system to prevent incidents of not able to control smart plug, for example, the system operates in other functions until it is unable to receive commands from the user, causing it is unable to control the plug too, etc. Therefore, error test of control system is an important practice in order to find the testing results whether the system hardware can cooperate with software systems effectively or not. The experiment will be tested by pressing the button on the plug and note whether it works properly according to the command or not. In this experiment, we test the Smart Plug operating in 3 different states: 1) When the plug is not connected to the internet, 2) When the plug is connected to the internet, and 3) When the plug is connected to the internet but the internet signal is unstable. The reason for testing the control system in various states is that the test of the button operation and the basic program are primary affect to pressing the button first. When pressing the button, even if in any state, it must always activate as ordered. For the purpose of not causing incidents of uncontrollable plugs. Therefore, this test is very important to find error in control system. The experiment results are as shown in Table 4.2.

**Table 4.2 Testing of control system errors**

<b>Times of error testing (times)</b>	<b>Number of control data transmission error (times)</b>		
	<b>Control manually by plug switching</b>	<b>Control via stable internet connection</b>	<b>Control unstable internet connection (110 dBm)</b>
1-100	0	0	0
100-200	0	0	0
200-300	0	0	0
300-400	0	0	0
400-500	0	0	0
500-600	0	0	0
600-700	0	0	0
700-800	0	0	0
800-900	0	0	0
900-1000	0	0	0

In regards to Table 4.2, the testing of the data transmission of above mentioned three states including 1) When the plug is not connected to the internet. 2) When the plug is connected to the internet. and 3) When the plug is connected to the internet but the internet signal is unstable (110 dBm). The results of all 1,000 experiments showed that there were no errors in the program running in all 3 states. Therefore, it is concluded that Hardware can cooperate well with the software.

### 3. Testing for sensor accuracy

The accuracy testing of the measurement system is an important test because the measurement system is the core of the Monitoring system. Since the monitoring system requires data from the sensor for calculating and displaying the results to users. Therefore, if the measurement system is not accurate, it will affect the data usage. The smart plug system contains 2 sensors : electric current sensor and Voltage sensor. The results of sensor accuracy are as following topics:

#### 3.1. Testing and validation of the voltage measurement system

Testing and validation of the voltage measurement system is a measurement to check for the efficiency of the measurement system of electric consumption rate of the device connected to the Smart plugs by using multi-meter to measure the voltage, then comparing the measured value from the hardware. The researcher conducted a total of 5 tests using 10 different voltages, namely 90, 120, 140, 160, 180, 200, 220, 240, 260 and 280 volts, which obtained the test result as shown in Table 4.3. Regarding to the test, we can summarize the test results and find the correctness of the measurement system as follow. The accuracy of the measurement system is accurate with an average error of only 0.29 percent considered to be acceptable with a high accuracy. In regard to the experiment results, it was found that there will have a high error rate when measuring in low voltage range. It can be seen that when we make a test at the voltage of 90 volts, we found an error up to 0.89%. However, the obtained value is still considered in the range of accuracy.



**Table 4.3 Determining the accuracy of the voltage measurement system**

Input Voltage (V)	Experimental voltage measurement (V)					Average (V)	% Error (%)
	1	2	3	4	5		
90	87	92	91	88	96	90.8	0.89
120	123	117	124	115	122	120.2	0.17
140	137	139	142	141	142	140.2	0.14
160	159	157	159	161	162	159.6	0.25
180	182	183	178	181	179	180.6	0.33
200	202	199	203	201	201	201.2	0.60
220	222	220	217	219	224	220.4	0.18
240	241	243	242	239	237	240.4	0.17
260	263	261	259	257	260	260	0.00
280	278	282	278	281	278	279.4	0.21

### 3.2. Testing and validation of the electric current measurement

Testing and validation of the electric current measurement system is a measure to validate the efficiency of the flow rate measuring system of electricity from devices connected to Smart plugs by using a multi-meter to measure electric current, then compare with the resulting values measured from the hardware. There are 5 tests conducted using 9 different currents including 1, 1.5, 2, 2.5, 3, 3.5, 4, 4.5 and 5 Ampere which obtained the test results as presented in Table 4.4. Regarding to the test, it was found that the accuracy of the current measurement system had an average error of only 3.57 percent. As a result, the value of the error is accurately acceptable.

**Table 4.4 Accuracy testing of the electrical current measurement system**

Current (A)	Experimental current measurement (A)					Average (A)	% Error (%)
	1	2	3	4	5		
1	0.87	1.27	0.94	1.34	1.11	1.11	11.00
1.5	1.4	1.58	1.46	1.78	1.52	1.55	3.33
2	2.24	2.22	2.05	1.98	1.99	2.10	5.00
2.5	2.56	2.65	2.49	2.37	2.15	2.44	2.40
3	2.87	3.23	3.04	3.34	3.07	3.11	3.67
3.5	3.39	3.64	3.78	3.57	3.57	3.59	2.57
4	4.27	4.31	4.12	3.97	3.99	4.13	3.25
4.5	4.4	4.59	4.47	4.82	4.56	4.57	1.56
5	5.12	5.23	4.93	4.7	5.07	5.01	0.20

**Accuracy of the display screen**

Regarding the accuracy test of the display screen is a test to find an error of the display system, as well as to verify that the system has displayed the functionality accurately and completely as designed. The testing method is done by tester's consideration that the entire website system has the correct display window according to the design accurately and completely. If there is an operating window as specified, therefore the system is considered to pass the test. Referring to the test, it was found that all the display screens were able to display the results correctly. The test details are as shown in Table 4.5

**Table 4.5 Website test schedule**

Website page	Test result
Home	✓
Add plugs	✓
Edit plug	✓
Remove plug	✓
Add group	✓
Edit group information	✓
Remove group	✓
Add group members	✓
Find Friends	✓
Manage friend's information	✓
Unfollow friend	✓
Control plug	✓
Edit profile	✓
Edit personal photos	✓
Notification system	✓
Power consumption statistics	✓
Event log	✓

Table 4.5 presents test results if the system display page as specified. The table shows that the system completely displays website window according to prior designed. We can see the sample details as shown in section 1 and 2. From the above topic, the content of the table presentation is divided into 2 parts in order to provide examples of the website window more easily. Because the website design is created to be able to adjust the shape according to the device activated, for instance, displaying results via a web browser and displaying the results via mobile phone as following details.

Data display via a web browser

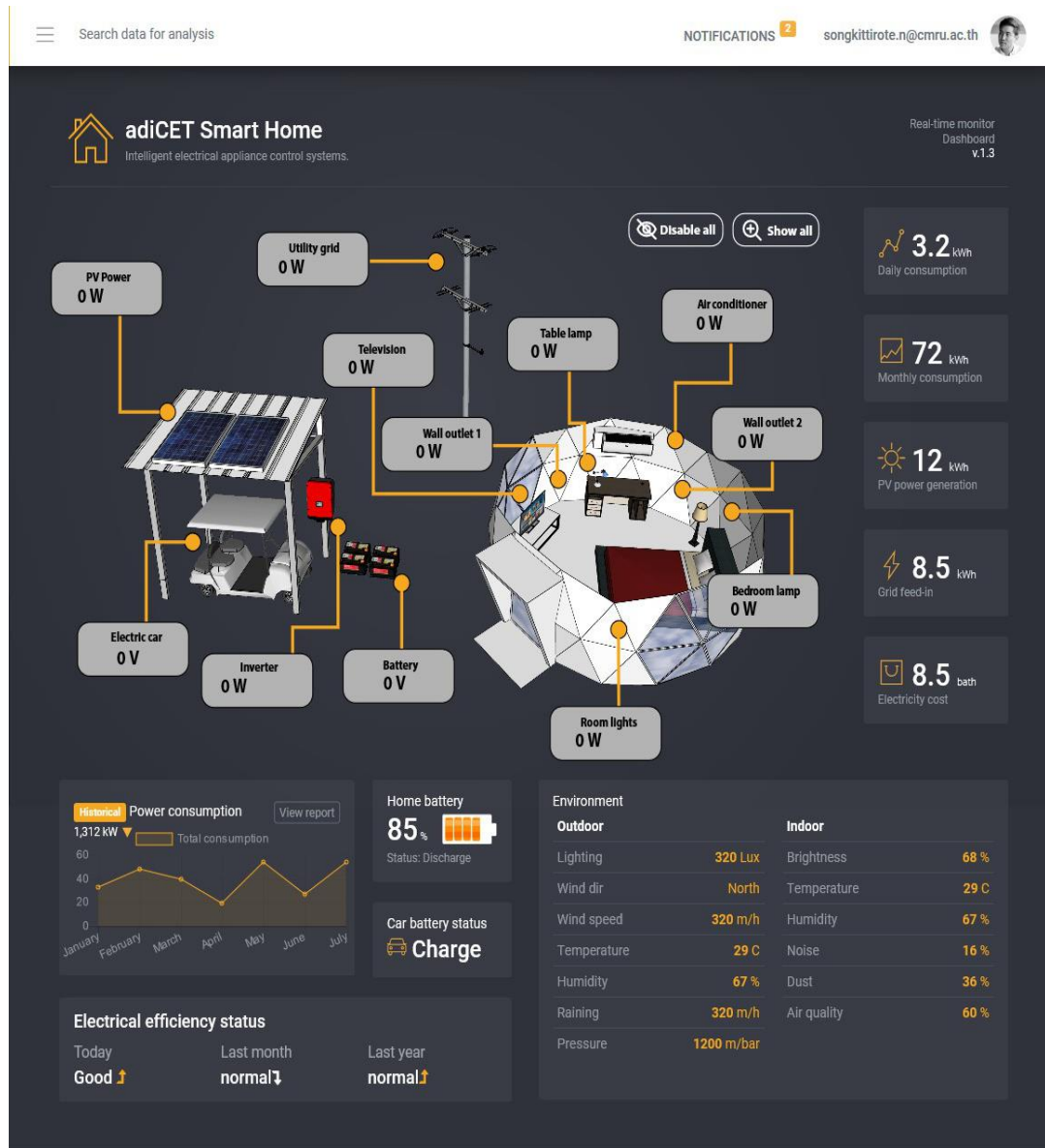


Figure 4.7 Main page

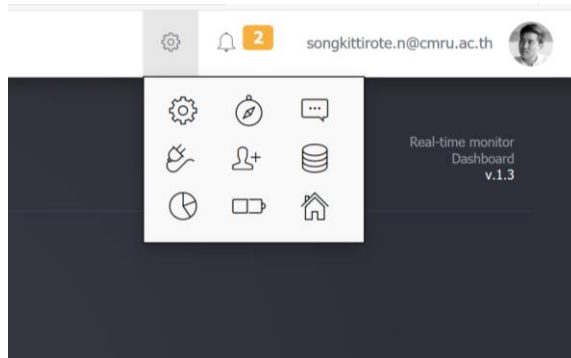


Figure 4.8 Quick menu

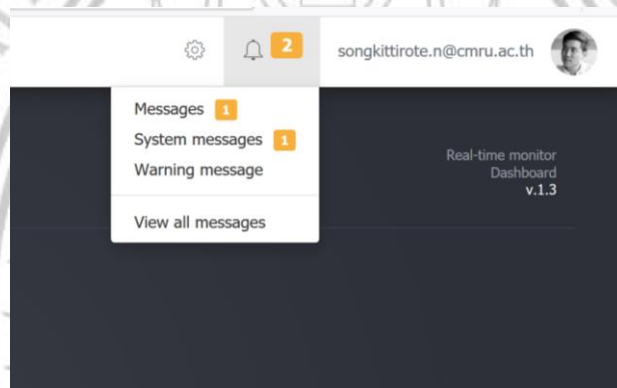


Figure 4.9 Notification menu

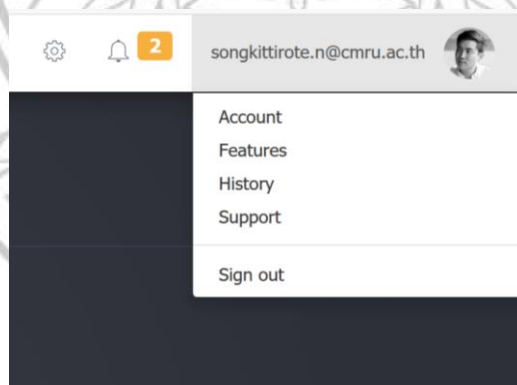


Figure 4.10 Profile settings



Figure 4.11 Side menu

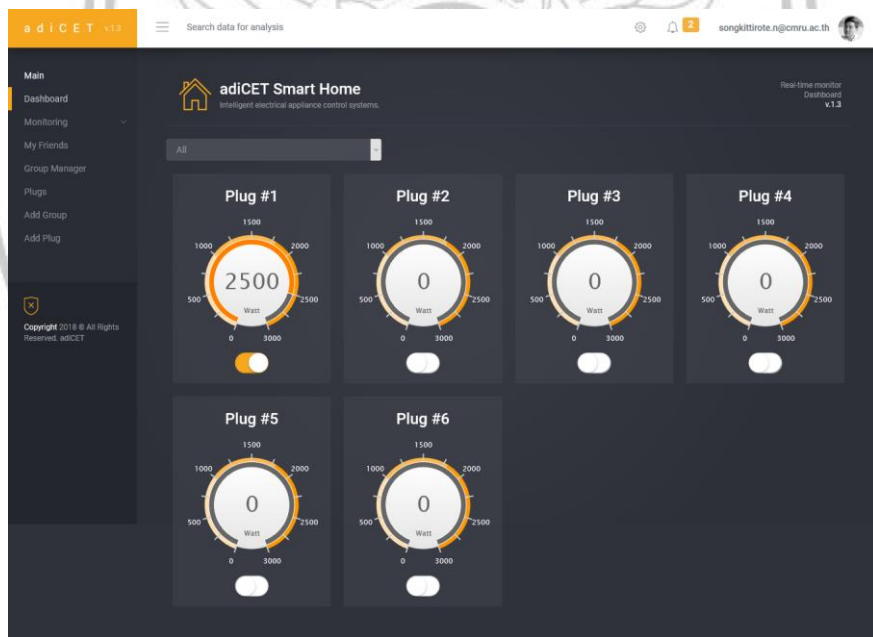
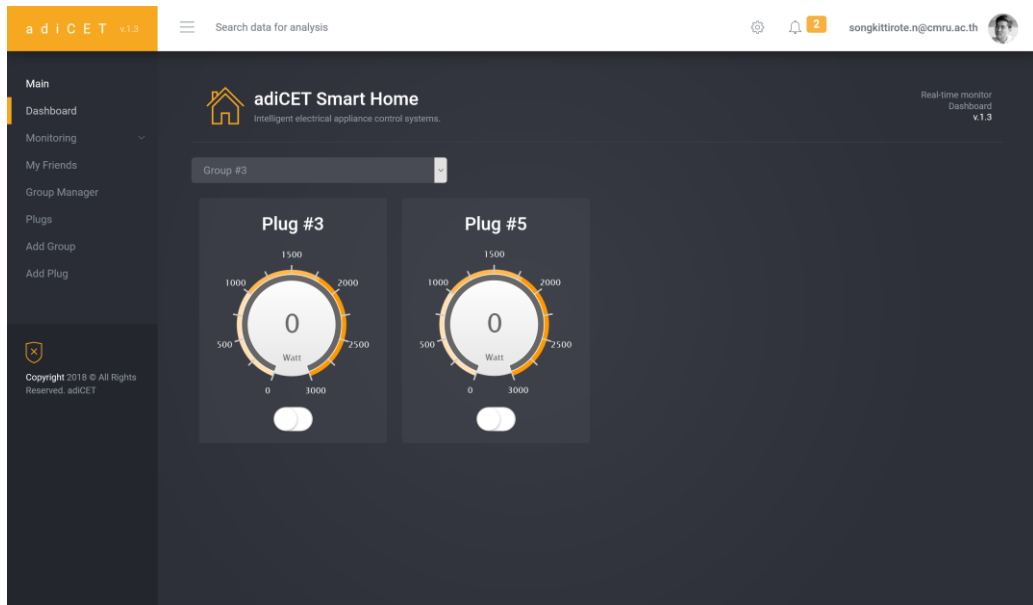
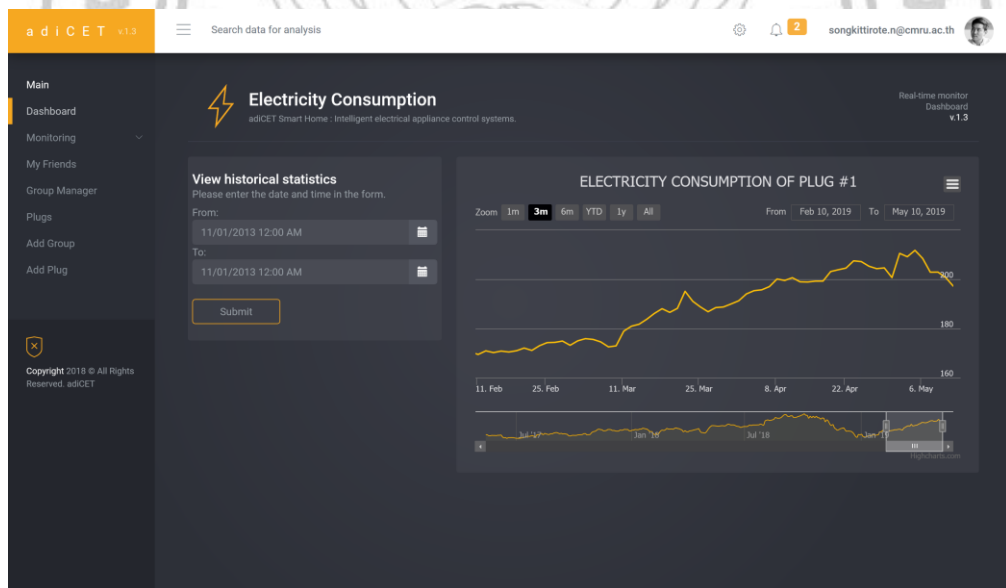


Figure 4.12 Smart plug control page



**Figure 4.13** Smart Plug information page as specified by the user



**Figure 4.14** History of electricity usage page.

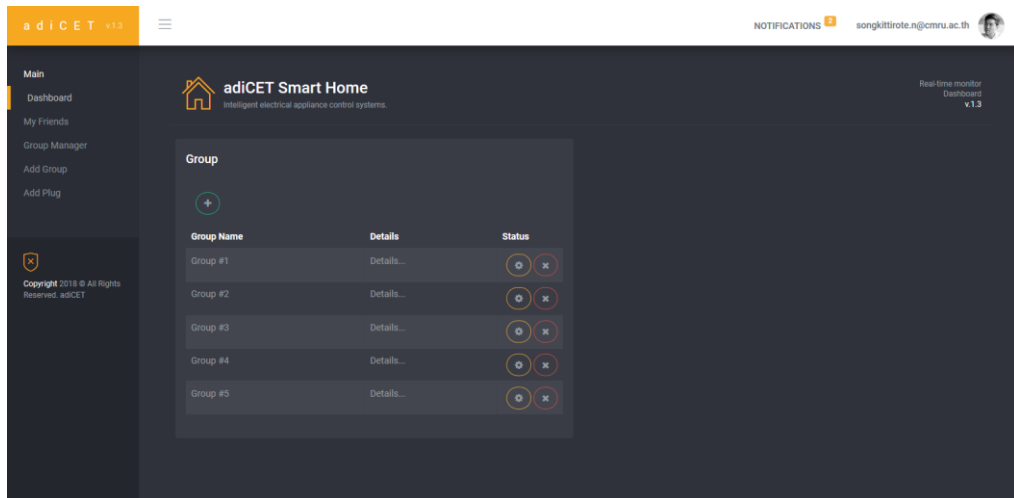


Figure 4.15 Group details page

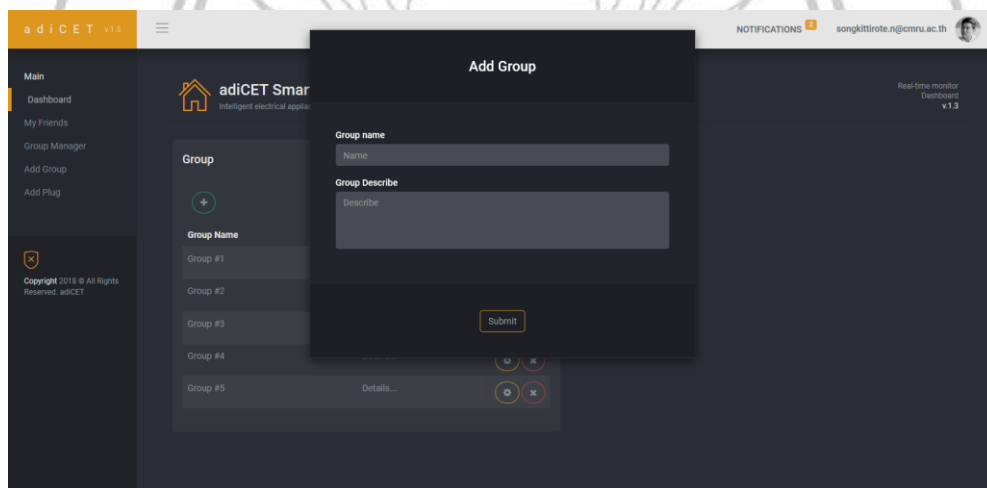


Figure 4.16 Example of adding a group



adiCET v1.3

songkittirote.n@cmru.ac.th

Real-time monitor Dashboard v1.3

adiCET Smart Home  
Intelligent electrical appliance control systems.

Group #1

Group Describe :  
Simple Group Describe here.

Plugs

List plugs in your group.

Plug Name	Status	Menu
Plug #1	ON	⊙ ✕
Plug #2	ON	⊙ ✕
Plug #3	ON	⊙ ✕
Plug #4	OFF	⊙ ✕
Plug #5	OFF	⊙ ✕

Member

Name	Phone	Remove
Kane John	055 1753 4032	✕
Caolmhe Person	0313 143 2317	✕
Danielle Gutierrez	076 1743 8649	✕
Meg Palmer	0863 826 7513	✕
Vanessa Escobar	0845 46 45	✕
Josiah Coffey	0313 143 2317	✕
Hadi Burrows	0313 143 2317	✕
Lilian Donovan	0313 143 2317	✕
Rhydian McCullough	0313 143 2317	✕

Copyright 2018 © All Rights Reserved. adiCET

Figure 4.17 Group management page

adiCET v1.3

songkittirote.n@cmru.ac.th

Real-time monitor Dashboard v1.3

adiCET Sma  
Intelligent electrical app.

Group #1

Group Describe :  
Simple Group Describe here.

Plugs

List plugs in your group.

Plug Name	Status	Menu
Plug #1	ON	⊙ ✕
Plug #2	ON	⊙ ✕
Plug #3	ON	⊙ ✕
Plug #4	OFF	⊙ ✕
Plug #5	OFF	⊙ ✕

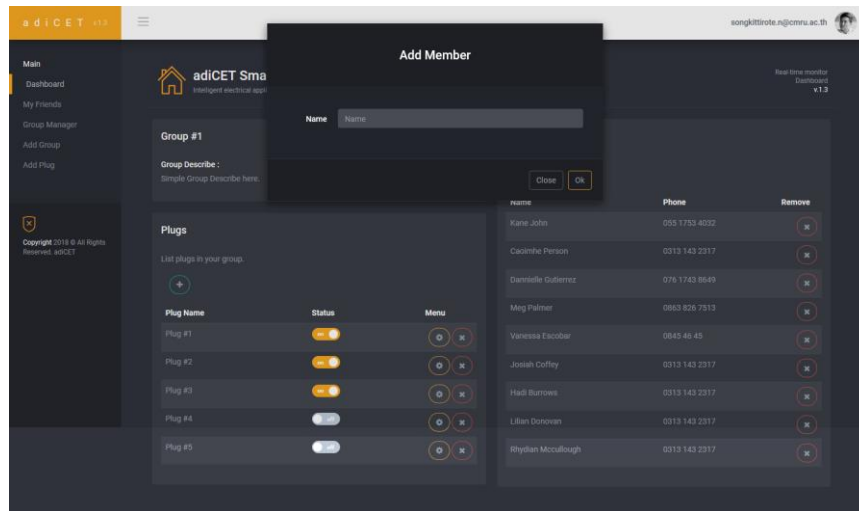
Member

Name	Phone	Remove
Kane John	055 1753 4032	✕
Caolmhe Person	0313 143 2317	✕
Danielle Gutierrez	076 1743 8649	✕
Meg Palmer	0863 826 7513	✕
Vanessa Escobar	0845 46 45	✕
Josiah Coffey	0313 143 2317	✕
Hadi Burrows	0313 143 2317	✕
Lilian Donovan	0313 143 2317	✕
Rhydian McCullough	0313 143 2317	✕

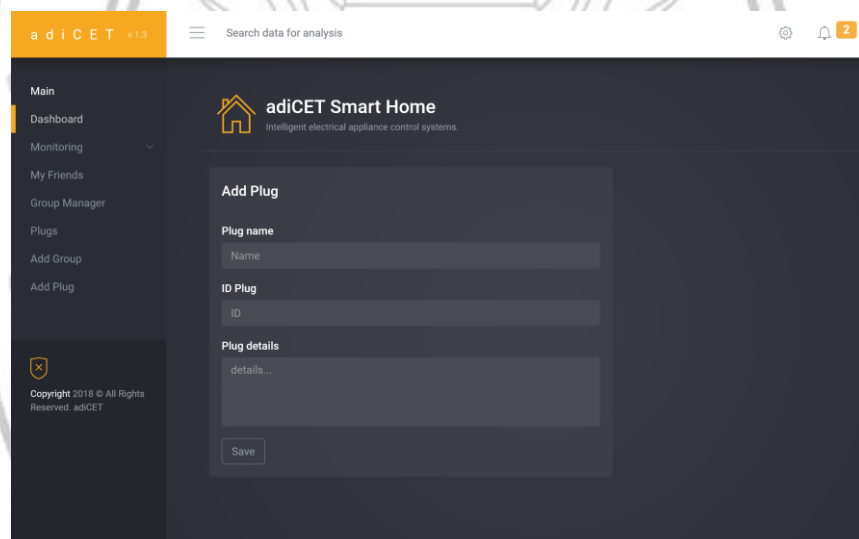
Close OK

Copyright 2018 © All Rights Reserved. adiCET

Figure 4.18 Example of adding smart plug to a group



**Figure 4.19** Example of adding members to a group



**Figure 4.20** Plug settings page for adding plugs into the system

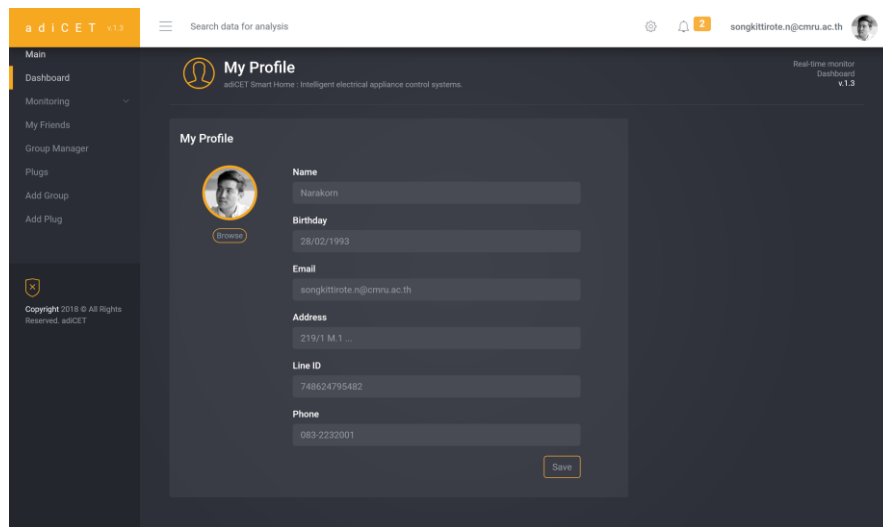


Figure 4.21 Profile edit page

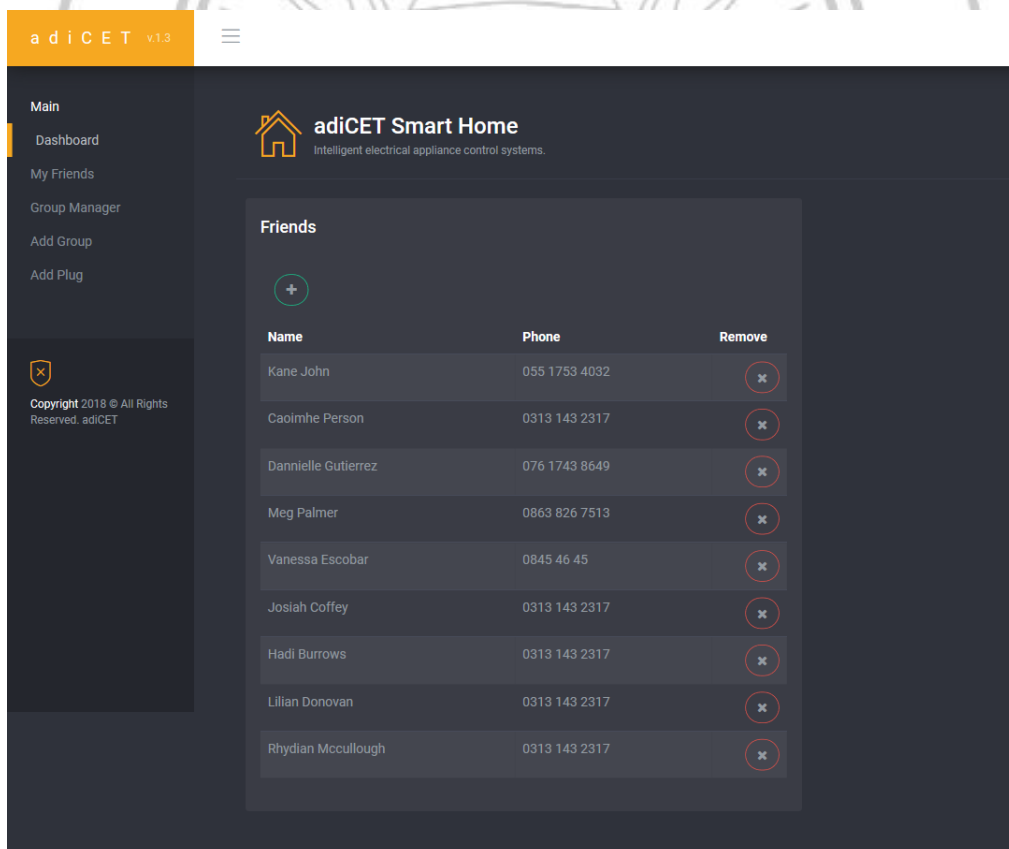


Figure 4.22 Friend management page

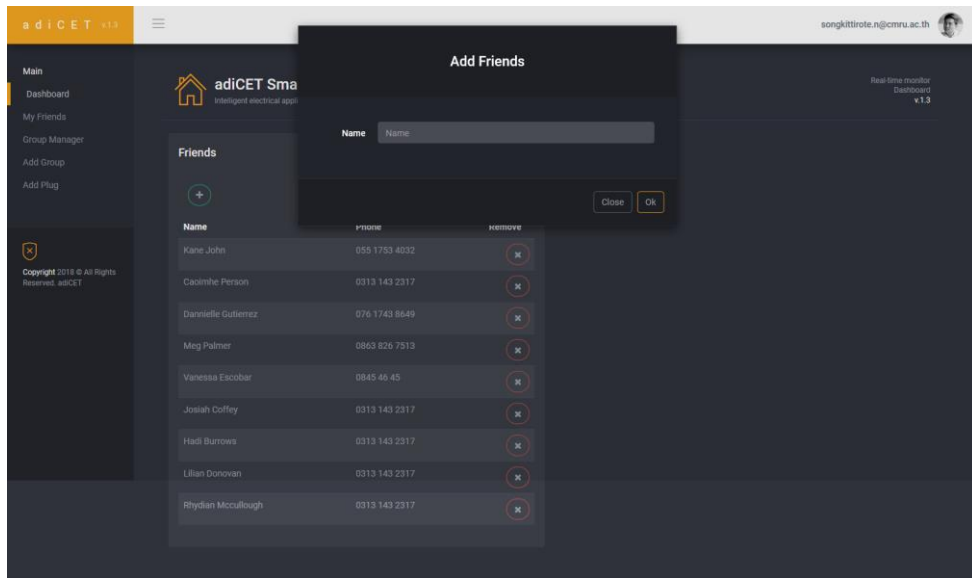


Figure 4.23 Finding friend system

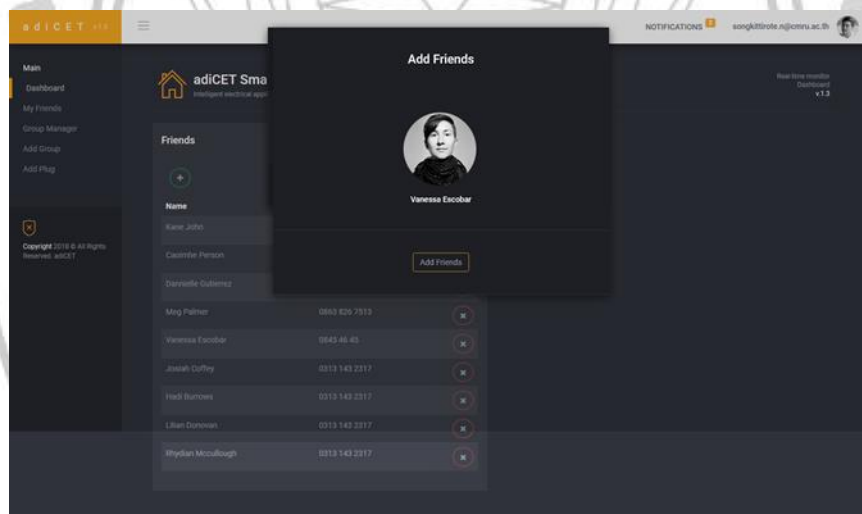


Figure 4.24 Function finds members found

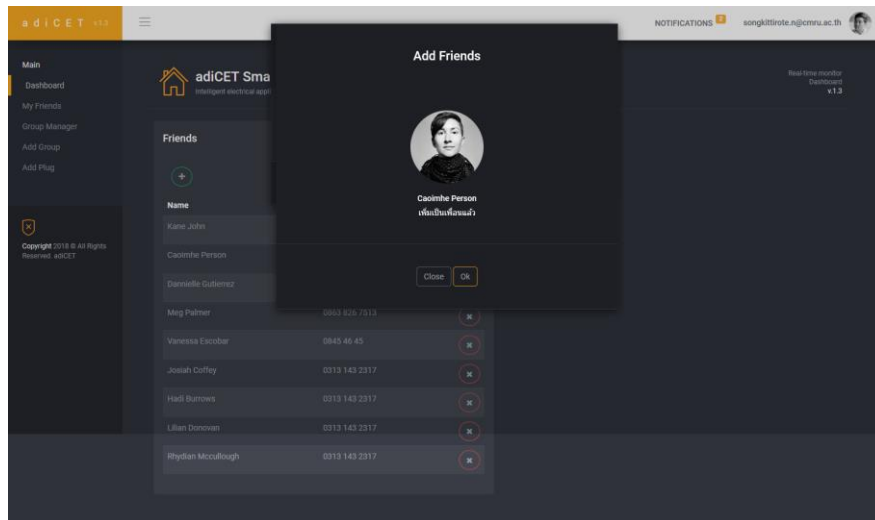


Figure 4.25 Example add member already

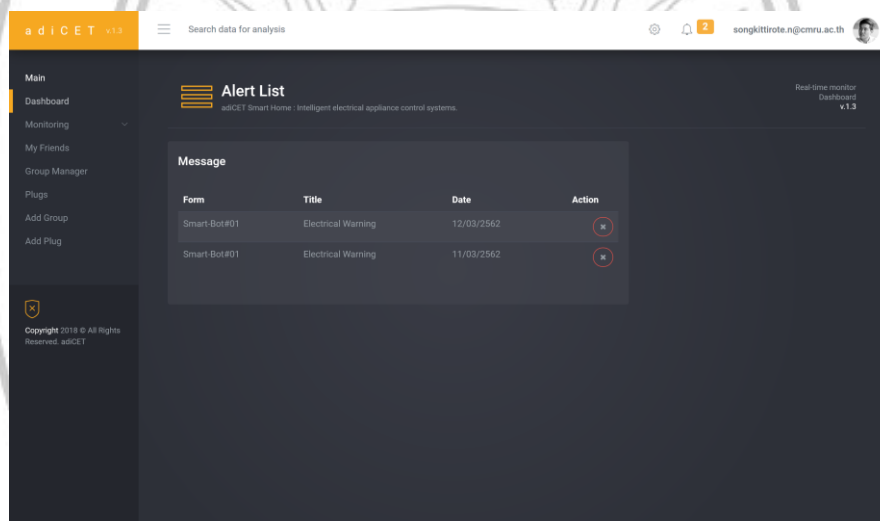
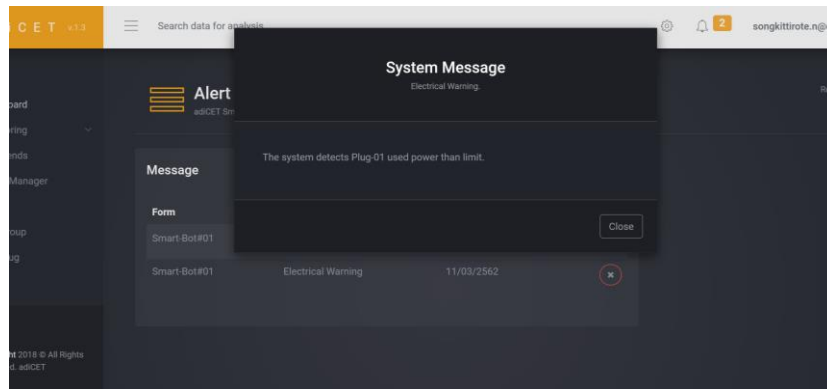
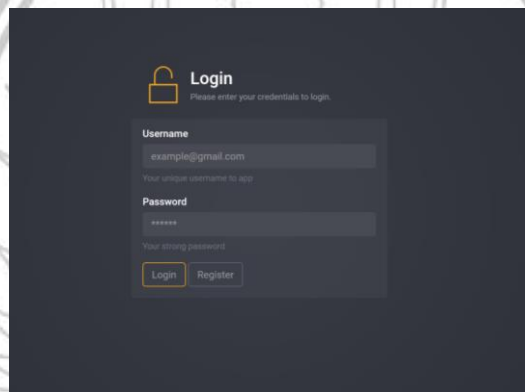


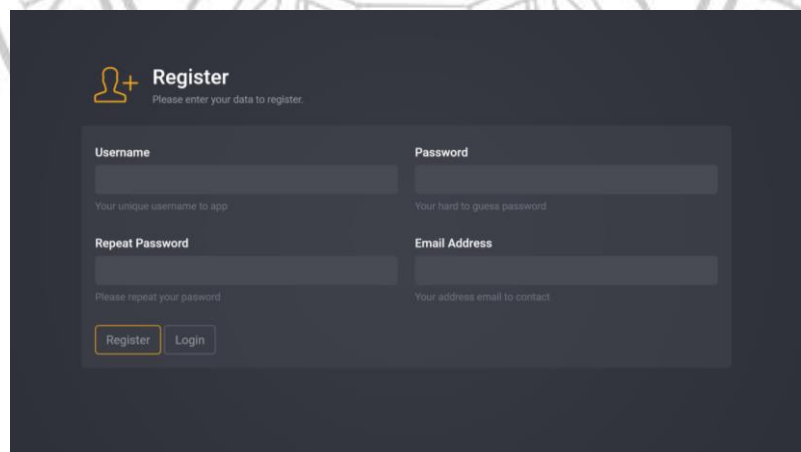
Figure 4.26 Notification page



**Figure 4.27** Notification message details



**Figure 4.28** Login page



**Figure 4.29** Membership page

Mobile data display

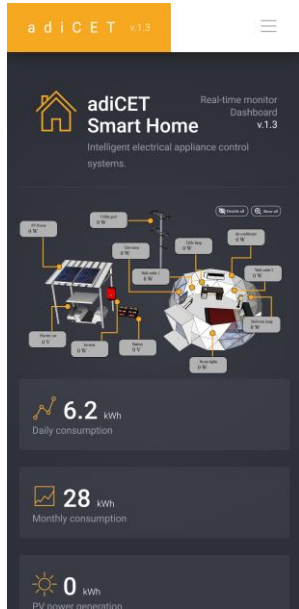


Figure 4.30 Main page

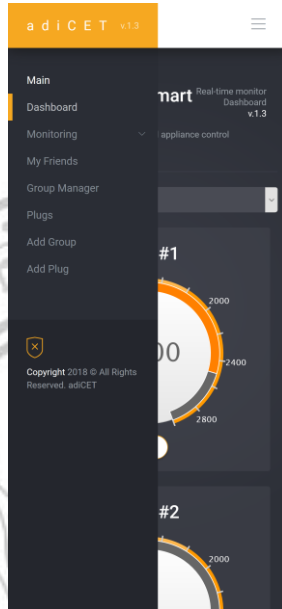


Figure 4.31 Side menu

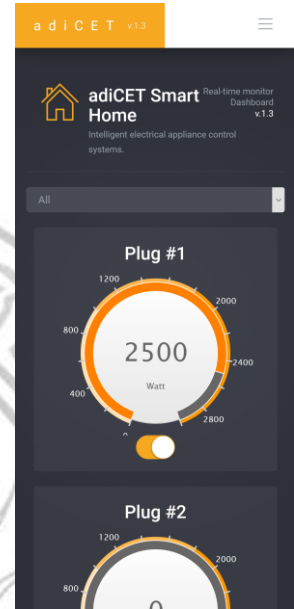


Figure 4.32 Plug control

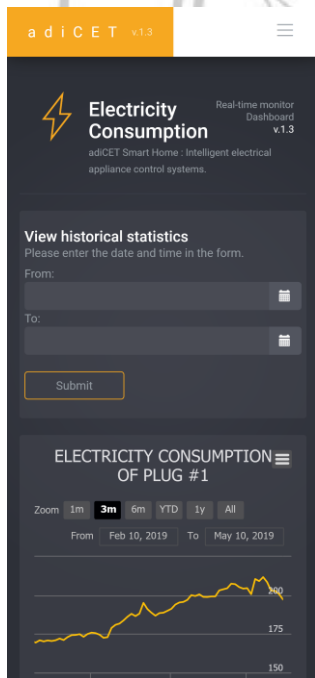


Figure 4.33 historical statistics

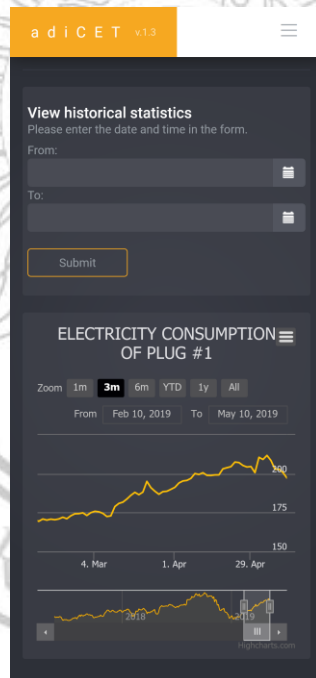


Figure 4.34 Electricity statistics

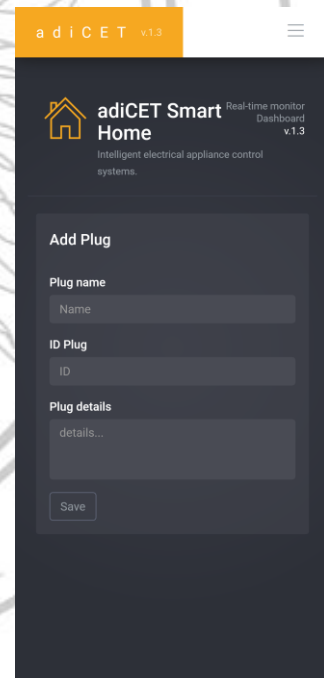


Figure 4.35 Add plug page

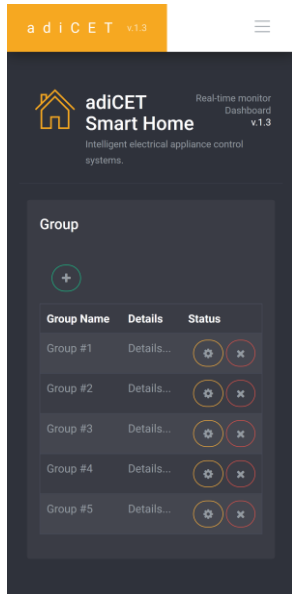


Figure 4.36 Group data

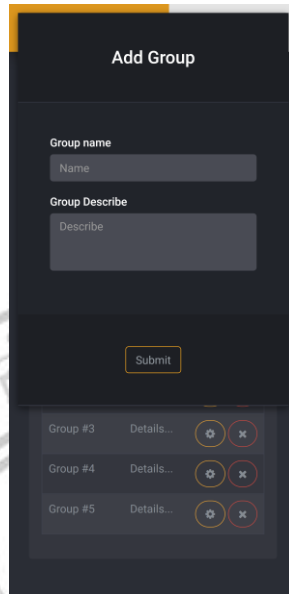


Figure 4.37 Add group information page

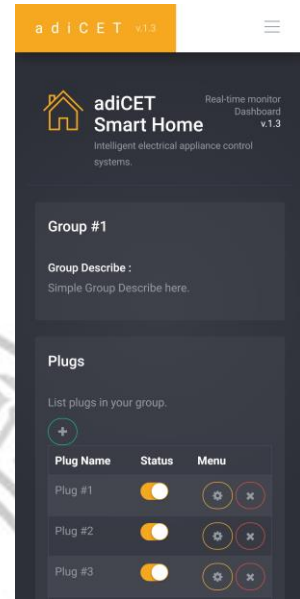


Figure 4.38 Plug management page

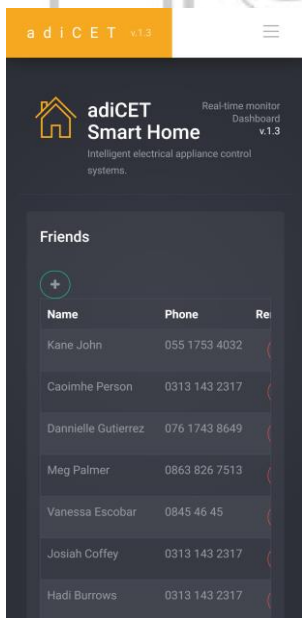


Figure 4.39 Friend info

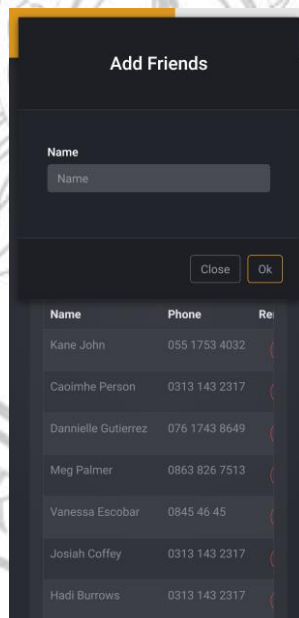


Figure 4.40 Friend finder window

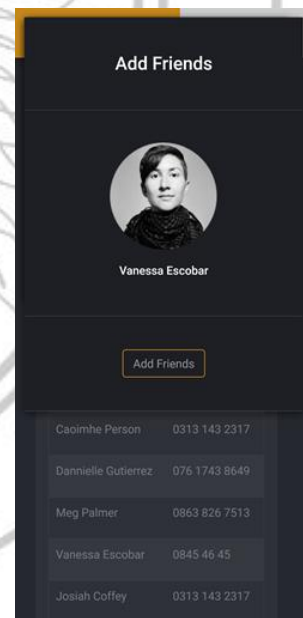
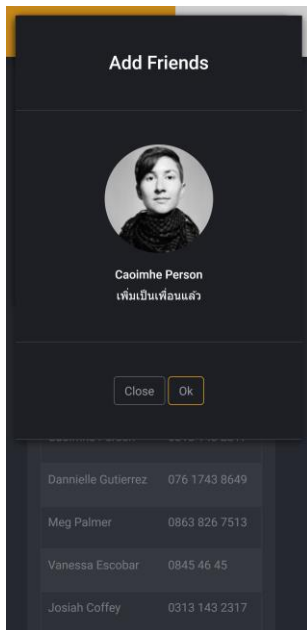
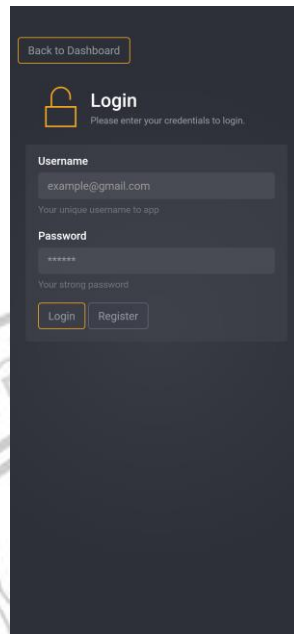


Figure 4.41 Find friends success

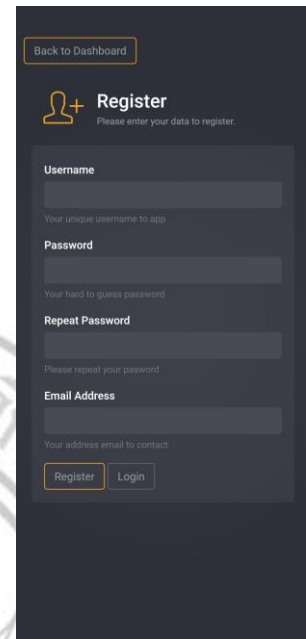




**Figure 4.42** Friends search



**Figure 4.43** Login page



**Figure 4.44** Register page

### Functional error test

Functional error test is to find error of all operating programs, including programs running in the hardware system, sending data, databases and device drivers via the web in order to test how many errors occurred in the overall system. Regarding to the test principle, we will divide the test into several parts as following details.

#### Program error test

The development of a Smart Plug control system to be able to operate as required needs a driver to determines the Smart Plug control requirements. Therefore, the program will run on the hardware and online system. To find errors in the program, it is done by finding errors in both systems working together whether they can work properly or not. The test can be described as follows:

##### 1. Program errors in the Hardware section

Program errors in the Hardware section is to find a mistake occurred in the Smart Plug system whether they can work correctly as specified or not. The process of error finding is important to indicate how secure the Smart Plug system is. This is because if the program set which determines the working principle does not follow the specified conditions, then it can cause harm to the user and the control system. The method of error testing is to test if Hardware system follows the algorithm designed as shown in Figure 3.2 (Hardware working principle). The researcher conducted 100 tests to find the error in each function by showing the work process as shown in the table.

**Table 4.6 Hardware system errors**

Function	Error (%)
Wi-Fi searching and settings	0
Can turn on plug when using electricity less than 3 A	0
Can turn off plug when using electricity more than 3 A	0
The status light blink when electricity usage more than 3 A..	0
Send electricity usage data via MQTT Protocol	0

Table 4.6 shows a test for each function, starting from testing the WIFI signal search system, connecting that signal and memorizing the test settings for cutting the circuit. However, the plug activates only when the system uses electricity for less than 3 A, and cut-off the work when using electricity for more than 3 A, then send alert the user through the status light. The system can transmit the readable data through the MQTT Protocol. Regarding to the testing of total 100 functional tests, there was no errors found. The experiment results was shown that the Smart Plug system can operate without errors, therefore it is considered highly stable.

## 2. Online programs error

The test in this section is to find error in the operation of all programs running in the online system. Those programs operate in different systems, but they must coordinate together. The test method of finding error of the program is needed to check for all functions if there is any error, which includes the details as shown in Table 4.7.

**Table 4.7 Online program error tests**

<b>Function</b>	<b>% Error (%)</b>
Web system	
Register	0.00
Edit Profile	0.00
Display personal information	0.00
Login	0.00
Add plugs	0.00
Edit plug	0.00
Remove plug	0.00
Display plug data	0.00

**Table 4.7 Online program error tests (Cont.)**

<b>Function</b>	<b>% Error (%)</b>
Control the plug (receive / send data from MQTT)	0.00
Show electricity usage statistics	0.00
Line Messenger system	
Register bot member	0.00
Cancel bot member	0.00
Send data via Line MSG	0.00
Line Bot	0.00
Server-side Script	
MQTT Server	0.00
Record results data from MQTT	0.00
Check electricity usage data	0.00
Alert notification	0.00

Table 4.7 show experimental results to find errors in each function. We conducted a total of 5 time to determine which function was found errors. The test can be divided into 3 categories. The first category is to test the website system including functions of Member Subscription, Edit Profile, Display Personal Data, Access into the system, Display the Plug Data, Edit, Add, Delete the Plug Data and Display Electricity Usage Statistics. Category 2 is to test the function of the Data Transmission System via Line Massager including functions of Register to receive information, Cancel membership status and Send data via Line Massager. Category 3 is to test the Server-side Script, the program running automatically on the server system. It consists of the following functions, namely Record data in MQTT, Check the electricity usage data and transmit the data to the messaging system. Regarding above mentioned experiment divided into 3 categories, it was found no error in the system and therefore concluded that the system was highly stable.

### Testing of program errors for system administrators

Testing of program errors for system administrators is to test program on the web application if it operates correctly or not. This test will help to know if the system for managing and displaying the data of the administrator can work correctly or not. The experiment method includes a total of 5 tests consisting of the details as shown in Table 4.8.

**Table 4.8 System administrator error**

Function	% Error (%)
Membership system	
Members detail	0.00
Manage member information	0.00
Manage the plug	
Displays plug information.	0.00
Manage plug data	0.00
Report system	
Report electricity consumption	0.00

Table 4.8 is to find the performance of functions for administrators including the following functions, namely View member information, Manage member information, Display the plug data of each user, Manage the plug data of each user and Report electricity consumption rate of each user. Referring to the experiment of these 5 functions, there was no error occurred in the system.

### Notification program error

This experiment is to test the error of the notification program through the Line Application. In case that the user has used electricity exceed the specified values, the system will send alert to the registered Line account. The test method is creating a dummy load connected to the plug, switch on the dummy load at 3.1 Amp in order to test whether the system send alert to the user or not. It was found that the test results are according to Table 4.9 as follows.

**Table 4.9 Testing the accuracy of the notification program**

Number of trials	Number of errors (times)
0-10	0
11-20	0
21-30	0
31-40	0
41-50	0

Table 4.9 present the test result of 50 times alert notification. The test results were found no error in transmit data. Regarding the test results, it can be confirmed that the validation and notification system can operate well.

#### **Testing of error in online plug control**

This test is to find errors in online plug control by transmit on / off commands via the control web to Smart Plug. The test method consists of 4 steps, starting from

- 1) The tester presses the button to activate the control process via the control web.
- 2) Smart Plug system is activated according to the command received.
- 3) When the plug is activated, the tester will have to press the turn-off button via the control web.
- 4) Smart Plug system stop working according to the tested command. The test must follow the specified procedures continuously. If there is any error in the system at any procedure, it is considered not pass the test. 5 tests were conducted. Regarding to the experiment, a total of 5 tests were conducted. 1,000 errors will be found from each test. The test results are in accordance with the following table.

**Table 4.10 Control testing**

<b>Times</b>	<b>% Error (%)</b>
1-99	0
100-199	0
200-299	0
300-399	0
400-499	0
500-599	0
600-699	0
700-799	0
800-899	0
900-1000	0

Table 4.10 shows a test of error in control system using internet at a speed of 4 Mbps. The results of the above tests showed no errors occurred in control system. But even if the program does not have an error, each transmission takes different time to transmit data from the server to the Smart Plug. The maximum speed of data transmission is 0.98 seconds and 0.243 seconds for minimum speed. Regarding to the obtained values, it can be seen that there are many different in the speed values. The researcher therefore assumed that the different time for data transmission was an error caused by uncontrollable variables, such as bad internet signal, other interference signals occurred, etc. However, the data transmission is still considered high speed. Therefore we can conclude that the control system is stable. In addition, the design and development of Smart Plug system by applying MQTT Protocol helps online control system without any errors.

### Database error test

Regarding the database error test, it is necessary to test the results and data display from the database to find the error of using the database. However, this test aims to test the speed of recording data only, because the test of the data display already exists in section 4.2 (Accuracy of the display screen) and 4.3 (Functional error tests). The above topic concerns the test of applying data from the database to display. Therefore it doesn't need to repeat the test. The method of testing for errors in data recording to the database is to find the speed limit that the system can perform well. The experiment starts from the beginning of the data transmission process from the client to the result recording system. The experiment method starts from transmitting data from Clients. In each client, the data will be sent in numbers 1 to 1,000 to the result recording system, then the system record that data into the InfluxDB Database Version 1.7. In order to find errors, it can be seen from the orderly arranged numbers. If there is a cross of numbers, it means the database cannot record the results in time. In this experiment, the data transmission will be tested at different speeds, including 10 seconds, 5 seconds, 1 second and 100 milliseconds. Experimental results are as shown in Table 4.11.

**Table 4.11 Database errors test at different time interval**

Times	Number of errors at different time interval (Times)			
	10 s	5 s	1 s	100 ms
1-100	0	0	0	5
100-200	0	0	0	9
200-300	0	0	0	16
300-400	0	0	0	7
400-500	0	0	0	14
500-600	0	0	0	4
600-700	0	0	0	6
700-800	0	0	0	7
800-900	0	0	0	4
900-1000	0	0	0	6



Table 4.11 shows database errors test at time interval of 10, 5, 1 and 0.1s. It was found that the data transmission from clients will have no error occurred at all if the frequency of data transmission is in the range of 1 - 10 seconds. On the contrary, if the frequency of data transmission to record the results is in the range of less than 1 second, there may be an error in recording the result. Therefore, this experiment concluded that the most appropriate frequency of data recording data is in the range of 1-10 seconds.

### **System speed test**

Smart Plug system relies on multiple system interoperability. Therefore, the speed test must be separated into several tests so that we can know the effective of the system, the speed limit, as well as limits of the program's usage. In regard to this speed test, only the speed of the operating online system is tested, because the hardware capability is already at a high speed in milliseconds, so no need to find the speed of receiving data or speed of decision processing. Therefore, the speed test can be done in the part of data transmission from hardware to the online system. Online system receives data to process and records of results and so on. Such test can be described as follows:

#### **Data transmission time of MQTT Protocol**

MQTT is the core of the Smart Plug system, because the data transmission system relies on data transmission via MQTT Protocol to the server system. Therefore MQTT was considered the core of data transmission. Finding the data transmission speed of the Smart Plug system via the MQTT Protocol allowed us to know the speed limit for data transmission to find the proper time of each transmission process. Regarding to the speed test, we tested the data transmission from the Smart Plug to the MQTT Server system, then set the timer starting from sending the data until the server system receives that message. Each time, we increased the number of messages in multiples of each QoS to test how fast the data transmission was as well as how long did it take If sending a lot of data. The test results could be described as table 4.12.

**Table 4.12 Hardware transmission time test table**

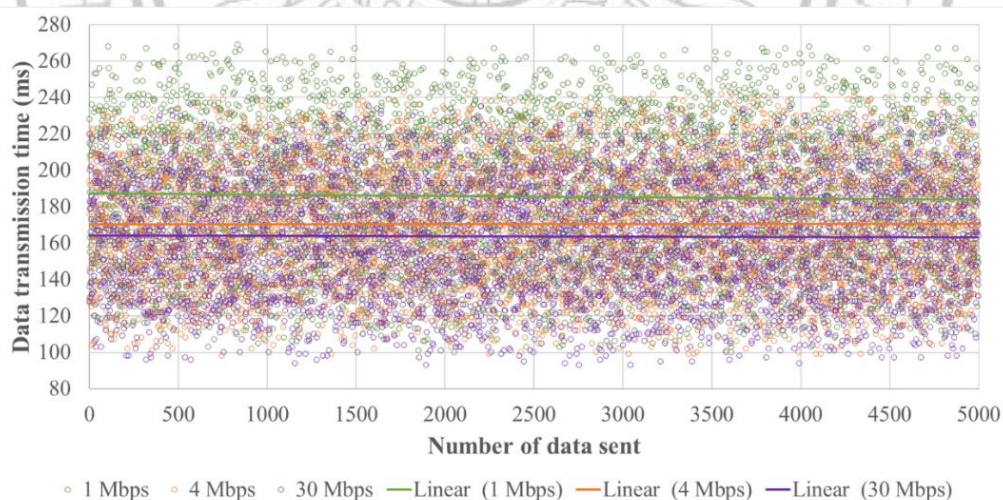
Data messages	The transmission time of sending hardware data via the MQTT protocol to the server. (ms)	
	QoS 0 in ms	QoS 2 in ms
1	26	173
2	36	459
5	45	1221
10	60	2629
100	201	17590
150	384	40100
500	687	116053
1000	1181	264265
10000	3976	1613806

From Table 4.12, the data obtained from the experiment is the data transmission from the hardware using the ESP8266 chipset with CPU frequency of 80MHz. We transmitted data via the 4 Mbps speed of Internet to Lenovo Server x3650 M5 Xeon E5-2660 v4 CPU frequency 2.0GHz Ram 16GB which installed MQTT Broker Version 1.5.8 of Mosquitto MQTT. Regarding the experiment table, it showed the average transmission time of each QoS. The figure showed that the average transmission time per 1 time message of QoS 0 was at 26 milliseconds and 173 milliseconds for QoS 2. Based on the mentioned figures, QoS 2 spent more time to send data than QoS 0 equal to 147 milliseconds. The reason of QoS 2 was slower than QoS 0 because QoS 2 was a messaging mode that gives higher priority to data transmission, causing many processes to be used to verify if the server receive the correct message, then it took longer time. In addition to QoS was a factor affecting the time of data transmission. There were other factors resulting in the transmission time, such as the frequency and number of messages in each transmission process. Regarding the table above, data transmission with high frequency directly affects the transmission time. Based on data analysis, the reason that the frequency of data transmission affects time

was that the hardware has limited CPU frequency. When trying to send large amounts of data required much time to calculate, as well as the factor of Internet speed. Therefore resulting in the test results as shown in Table 4.12, the greater the amount of data being sent, the higher speed.

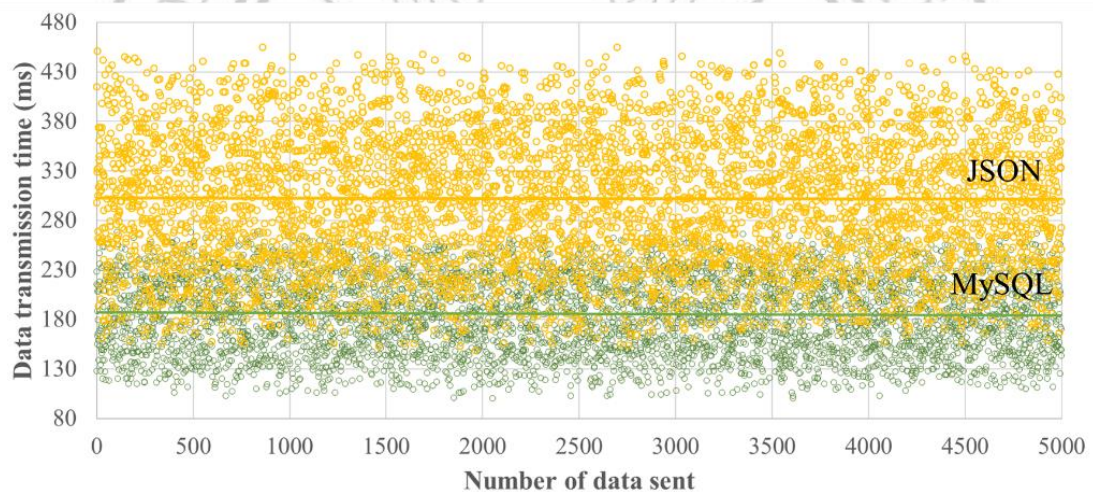
### Transmission time test for online smart plug control

transmission time test of the control helped us to know the efficiency of Smart Plug control through online system. The test method was to set the timer starting from sending data from the control web to the Smart Plug, then reckoned time with automatic test program. The test program was created to facilitate the testing of controls in large number. In this test, we conducted a total of 5,000 tests on each internet speed range connected to Smart Plug, namely 1, 4 and 30 Mbps. When starting the experiment, the test program automatically recorded the starting time into the Json file database. When MCU get commands obtained from online system to further order the Relay, the system sent the time back to the server to record the data. From the above steps, you will get time to control by each time (In the process before starting the test, the MCU and the server will be set as the same time base at Nano time level, when the time base was matched, then we could start testing). Regarding to the testing to find the control speed provided the test results as following figure.

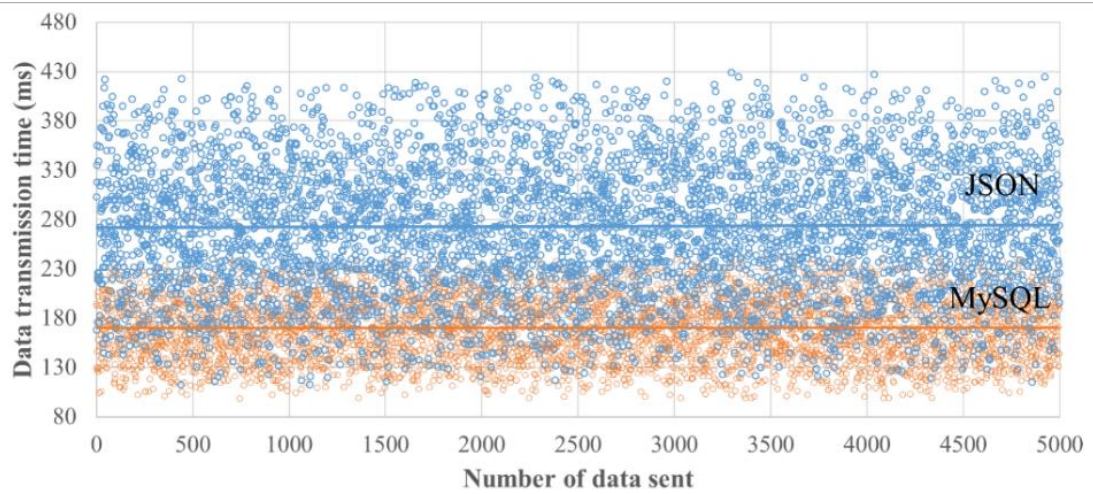


**Figure 4.45** Control transmission time results

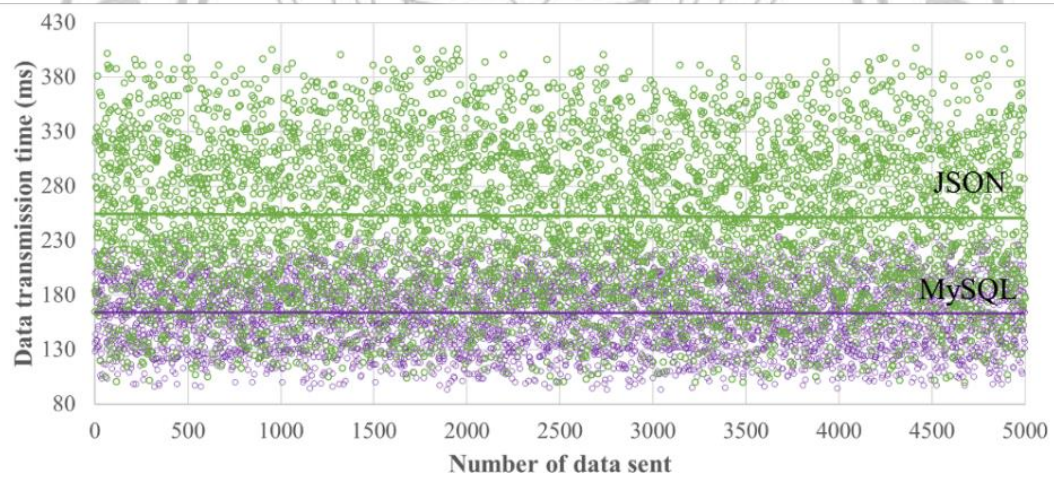
From Figure 4.45, the online plug system control test had an average transmission time of 276.04ms. It was considered a high-speed control system, although using the different speed of the internet, namely 1, 4, and 30 Mbps. However, the average transmission time considered similar including 302.23, 273.20, and 252.70. Referring to the above figures, it can be confirmed that the implementation of MQTT Protocol enabled the Smart Plug control system to work effectively. In addition, algorithms designed to coordinate together also affected the transmission time of control as well. It can be observed from the experimental results to compare the implementation of MySQL database to help memorize some data in the MQTT Protocol. The experiment results comparing the transmission time is as shown in the following figure.



**Figure 4.46** Data transmission time using JSON format and MySQL via internet 1 Mbps



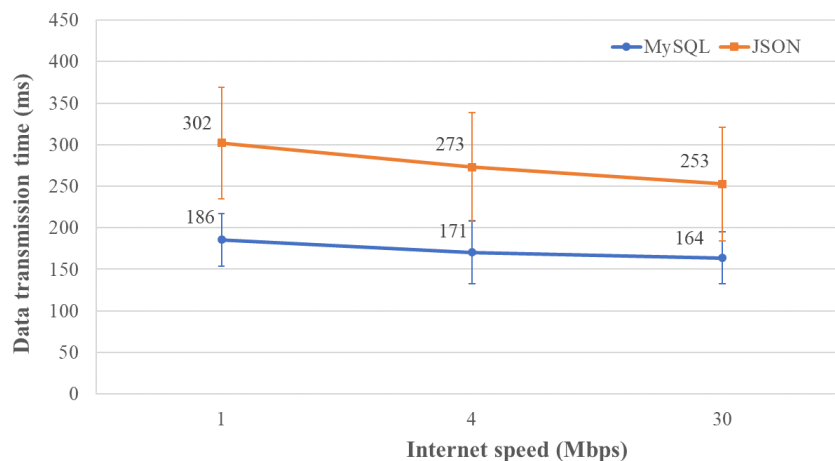
**Figure 4.47** Data transmission time using JSON format and MySQL via internet 4 Mbps



**Figure 4.48** Data transmission time using JSON format and MySQL via internet 30 Mbps

Figure 4.46-4.48 present the comparison of data transmission time between using JSON format and MySQL. The results showed that transmission time using JSON format and MySQL at internet speed of 1 Mbps data were in the range of 149-455 and 100-269 ms with average transmission time of 302 and 186 ms, respectively. At internet speed of 4 Mbps, transmission time using JSON format and MySQL were in the range

of 113-429 and 98-243 ms with average transmission time of 273 and 171 ms, respectively. Lastly, at internet speed of 30 Mbps, transmission time using JSON format and MySQL were in the range of 100-407 and 93-236 ms with average transmission time of 253 and 164 ms, respectively. The data transmission time was decreased when increasing the internet speed, as shown in Figure 4.47

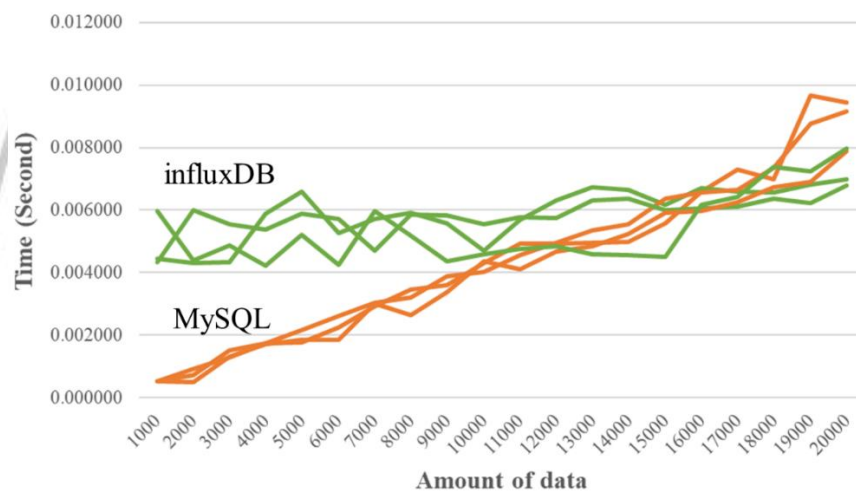


**Figure 4.49** Data transmission time using JSON format and MySQL

From Figure 4.49 when comparing to JSON format, the average data transmission time though MySQL could be reduced accounting for 39, 38 and 35% at internet speed of 1, 4, and 30 Mbps, respectively. This number presented that, the enhancement of data transmission speed exhibited higher performance at low internet speed (1 Mbps). Therefore, this protocol could be an alternative for rural area which has poor internet signal. It also could be used in the complex buildings or houses which has poor internet signal too. In addition, at higher internet speed (4 and 30 Mbps), the results showed that even the enhancement is decreased, the use of MySQL database exhibited greater data transmission time compared to those of JSON format. For JSON format, standard deviation for data transmission at 1, 4, and 30 Mbps were 67, 66, and 68 ms while standard deviation using MySQL format were 32, 38, and 3 ms. The experimental result showed that using MySQL exhibited lower standard deviation than JSON format. These results revealed that MySQL could be also applied to enhance repeatability in addition to data transmission time.

### Database transmission time test

Transmission time test of database system is to find the efficiency of implementing different databases. Since each database has a particular various abilities, the development of Smart Plug systems that rely on only one database system affected the flexibility of the database system reduced. Regarding to the system design in this research, MySQL and InfluxDB databases are used to coordinate together. The database transmission time test is therefore a comparison of the time of each type of database used. The time test results can be explained as shown in the figure 4.50.



**Figure 4.50** MySQL and InfluxDB data retrieval time

Figure 4.50 presented a test of retrieving data transmission time with different amount of data. The experimental method was about to test the data usage of MySQL and InfluxDB databases containing 1,000 to 10,000 data counts, then reckoned time since retrieving the data until the data was released. Based on the experimental results, MySQL had a higher transmission time than InfluxDB. The average time to retrieve 1,000 data from MySQL is 0.522 ms, as for the average time to retrieve data from InfluxDB is 4.914 seconds. Regarding to the above figure, MySQL spent more time when retrieving large amounts of data, but InfluxDB spent a fixed amount of time, regardless of the amount of data even small or large. In regard to the experiment, it can be concluded that the InfluxDB database is more suitable than MySQL for storing large

amount of repetitive data, such as electricity consumption data or incidents arising from the use of electricity. MySQL is suitable for storing uncomplicated data or related data, such as User information, Configuration information Sensor detail information, etc. In conclusion, if applying both databases together, it helps the system to have a higher transmission time.





## CHAPTER 5

### CONCLUSION AND RECOMMENDATIONS

This research aims to create a smart plug system for direct current which is able to be controlled via the internet system. The design and development of such system implements hardware and software technologies to coordinate together causing the most effective system. The hardware is a device receiving commands to control electric appliances connected to the plug. The system can recognize that the connected power supply is DC or AC. If the power supply is correct, the system will activate the plug to operate normally. The plug system will be able to search for WIFI signals and connect itself automatically which enables the plug system to connect to the Internet in order to receive control signals from online systems. In addition, hardware system also consists of sensors to measure electric current and voltage for recording historical electricity usage statistics. If the plug uses electricity (A) more than specified, the system will automatically shut down. For safety in using, to make the hardware system work correctly as required, it requires good software to manage in order to reduce any errors, causing the overall system be safe, convenient and fast. The software will operate in many parts for making the system in stable, it operates in 2 main parts, namely 1) Operating inside the Smart Plug. In this part, the software will determine the basic operation algorithm of the plug, such as receiving values from the keypad, the cut-off sensor to control the on-off switch, Wifi signal search, Internet connection and receiving and exporting data to the server, etc. 2. Software operating on online system. It contacts the users to facilitate them to control and set up the plug conveniently. Furthermore, there is some software working in the background to help the system become more stable. The development of these two parts of the system makes the Smart Plug system be more effective. The development of Smart Plug for DC power enables us to use DC power more safely as well as help facilitate the users, resulting in the use

of electrical energy for maximum efficiency. In addition, the knowledge can be applied to other researches. The development results can be described as follows.

### **Conclusion**

The design and development of the Smart Plug system requires the application of various knowledge and technologies to have the system efficient, fast and safe. In addition, the development of Smart Plug system also needs to consider the user's convenience as well (Hamdan, Shanableh, Zaki, Al-Ali, & Shanableh, 2019; Liu, Yang, & Deng, 2018). In regard to developing the Smart Plug system, in addition to support the connection and be able to control the DC power, it must also be intelligent and able to reduce the difficulty of using electricity as well as able to operate when connecting to a low-speed internet. Therefore, the development of the Smart Plug system to meet the above requirements seems challenging and difficult. This research presented the concept of implementing the communication technology and Cloud systems to help reduce the workload of hardware. It causes the hardware system smaller, use less resources and be more intelligent. We can apply a cloud system with a large data storage area to help calculate various data while minimizing the data to a small size, then submitting the processed data back to the Hardware. This method can help to reduce limitations of hardware capabilities, such as advance forecasting, Notification via Line Messenger Application, remembering user behavior, etc (Iqbal, Lee, & Hall, 2018; Tao, Zuo, Liu, Castiglione, & Palmieri, 2018; Zhang et al., 2018). Based on the experiment results, it is confirmed that applying various technologies together affect the efficient Smart Plug system. The systems operating separately can coordinate together excellently. The system can operate correctly as designed. The test results can be described by the following topics.

### **The development of electronic circuit board**

The Protoboard is a device allowing user to control the electrical circuit breaker of electric appliances. The principle of developing an electronic board to control electric appliances and receive commands, and data from the internet must rely on MCUs communicating with WIFI signals. At present, there are many technologies that enable MCU to connect to the internet system. In this research, we used the ESP8266 12E chipset with CPU frequency at 80MHz. ESP8266 is a small and cheap chipset with special ability to connect with WIFI under IEEE 802.11 standard. Application of such chipsets let us to connect with the TCP Network system for using MQTT Protocol with the bidirectional communication. Based on the capabilities of ESP8266, when applying the relay circuit and sensor circuit, it allows us to control the Smart Plug via online system. Relay circuits controlling electric appliances use General Relay containing the principle of magnetizing the contact of contactor with electromagnets to change the state from NO (Normally Open) to NC (Normally Closed). The reason of applying the General Relay because it is only a few relay types which can be used with the DC system. The disadvantage of using the General Relay affecting the system is that a noise occurred when the electromagnetic magnetizes the contact of the contactor. In addition, General Relay is not designed for applying with DC power systems. Once used, it may cause Arc Flash easily. Regarding to the review of relevant literatures, Arc Flash can only occur when the voltage is high and the gap of the arc occurs (Zhao & Gao, 2018). To solve the Arc Flash problem, Smart Plug must be designed and developed to be compatible with electric appliances that do not consume 3 Amp power for being safe. Therefore, the sensor system must measure and cut-off the operation immediately. The design and development of the sensor system uses the principles of the Hall Effect and Voltage divider. The Hall Effect is an electrical phenomenon which it can be applied to measure electricity. Hall Effect is a phenomenon that charges moving within the conductor in the area of magnetic field moving together on one side of the conductor, causing power differences between the two sides of the conductor, then resulting in electricity between 0-5 Vdc. In this step, therefore we know the number of currents occurred. Regarding to measurement of Hall Effect in this research, the IC number ACS712 was used to measure current. Based on the implementing results, ACS712 showed an average error of 3.57 percent which is

considered a precise range. As for the voltage measurement uses the principle of voltage dividing of R-Divider. The working principle uses R1 and R2 resistors to serialize across the power supply. Regarding to Ohm's law, the pressure from the power source is divided between the two resistances, causing the output voltage to increase and decrease according to the obtained input. At this stage, we can use the MCU to read the measured voltage in order to apply the value to the Smart plug. The results showed only 0.29 percent of error. According to the test results of current and voltage measurement of the Smart Plug system, it can be considered that the development of the DC power sensor system can operate well. As for the operating of other systems such as Switching Power Supply supporting DC and AC, LED circuit for status notification, Push button circuit, Relay circuit, they operate well with stable. Regarding to the test results, there was no errors found. It can be concluded that the design and development of the electronic circuit board of the Smart Plug system can operate correctly without errors and in line with the research objectives.

#### **Software development**

Software development is the key to develop Smart Plug system, because Software determines the states and algorithm of the work. Therefore, creating good software results in effective performance. Software development is to develop the system to work on the platform in order to reduce the limits of various system. For example, developing programs operating on Cloud Computer to help calculate the data together with sending the processed data back to software running on a small MCU, etc. It can be seen that the programs operating in many parts of system play the important roles to encourage the Smart Plug system to work in stable and efficiently. The test results for the performance of software system can be divided into 2 topics as following details.

##### **1. Smart Plug Software testing**

The development of software running on Smart Plug is to set the initial algorithm of the system, enabling the Smart Plug to work properly as designed. The basic functions of the system include Receiving data from users via keypad, Connecting to the Internet system, WIFI setting system, Receiving data from MQTT Protocol, Converting voltage from sensor to digital data format, Turn-on/Turn-off operating function when using electricity within the specified ranges. The development of such

functions is processed by programming C++ Language on Arduino IDE, then flashing the code data into MCU, enabling MCU to work as designed. Regarding to the test results of 100 times functions test, there was no error. The system can operated completely as designed.

## 2. Testing software running on the online system

There are 3 programs running on the online system, including a program of web control and a web management program for administrators, a program of automatically record data communicated in the MQTT Protocol and the notification program via Line Application. The above three programs will be developed by using computer languages and operate in different systems. The program of web control and the web management program for administrators will be developed by using HTML, PHP, Java Script, MySQL, CSS languages operating on Nginx Web Server. The website program is a program connecting users and administrators. The website consists of functions for Set up a system connection, Smart Plug control system, Members management, View historical statistics. As for a program of automatically record data communicated in the MQTT Protocol and the notification program via Line Application use Java script language operating in Node-Red to manage the receiving data and process according to designed algorithm. The test results show that the system can operate all functions as designed without any errors.

From the test results of software running on Smart Plug and Online system coordinating together smoothly and not causing errors in work, the test results are as specified. Regarding to the development of software, in addition to have a software for controlling Smart Plug effectively. This development also lets us know implementing the advantages of each technology to coordinate together, causing the size reduction of the hardware but still remain the original performance and capabilities. In general technology, it tries to create an effective control system by relying on the hardware capabilities. Therefore, hardware must be in large size and expensive. In this research, the ESP8266 will be used so it will not be able to compare both Flash memory and Storage or CPU frequency that is not enough. However, according to the test results, implementing the software operating on the Cloud can reduce the limitations, because the hardware will operate according to their own uncomplicated algorithms and wait to receive data processed from the server side, resulting in no limitations on

the size and speed of hardware anymore. The result of the error test confirms the above concept very well.

### **Protocol development**

The protocol used for data transmission is essential to the Smart Plug control system. Due to the data transmission characteristics and control of Smart Plug are very complicated when there are many plugs connected as well as a lot of user access into the system which directly affect the traffic of the signal, causing the isthmus at the server area. MQTT Protocol has been applied to this research. It helps the Smart Plug control via the internet signal to be fast and stable. In addition, the application of MQTT allows the integrated system is able to effectively control Smart Plug, and support the transmission of large amounts of data as well. The experiment results presented that it can support 10,000 simultaneous commands taking only 3.976 seconds. MQTT is a protocol with Client / Server architecture having Hub-and-Spoke Topology, causing the online system to connect easily with the Smart Plug. The architecture relies on Publish and Subscribe according to the specified topic. Therefore, it can reduce the complexity of connection and data transmission of Smart Plug. When consisting less complexity, the hardware system takes the remaining RAM memory to operate other functions, resulting in more speed of Smart Plug control (Manohar & Reuban Gnana Asir, 2018; Matabuena, Bellido-Outeirino, Moreno-Munoz, Gil-de-Castro, & Flores-Arias, 2018; Nasr, Kfoury, & Khoury, 2019). Regarding to the experiment of transmitting data from Smart Plug to the server system with low speed internet at 1 Mbps. RSSI -92 dBm takes an average of 0.302 seconds to transmit data. According to the figure, it can be seen that even working on Internet system with low-speed and unstable, it can still operate well. In addition, the research also conducted 5,000 times error tests of Smart Plug data transmission by using the different internet speed connected to Smart Plug, ie 30 4 and 1 Mbps. to test for any errors in data transmission process. Regarding to the experiment results, there was no error in the data transmission even once. However, the data transmission each time took unequal time with an average time of 173.26 ms. The experiment results therefore concluded that although the MQTT system can help the data transmission system be stable. However, there are other variables affecting the stability and uncontrollable, such as WIFI signal quality, other noise, etc. Therefore, if wanting to transmit data without errors, it must calculate the complexity of the data

sent. Minimize the data size to allow data to be transmitted via low-quality WIFI signals. In this research, we see the problem and therefore apply MySQL database to coordinate together with MQTT Protocol. The implementation of the MySQL database to recognize some data enables the reduction of the messages size sent through the MQTT Protocol. The database system will reduce the data size, resulting in the data transmission each time using data size not more than 4 byte. When comparing the general process of data transmission which takes at least 114 bytes. Therefore, MySQL can reduce the message size by 96.61%. Regarding to the test of transmission time comparison in data transmission via MQTT, we compared the data transmission time between using common data formats of JSON format and applying MySQL. The test was found that reducing the size of the messages resulted in the transmission time decreasing 37.24% from 276.04 to 173.26ms. Based on the referred figures, it can be confirmed that the development of a good data transmission system affects more efficient in Smart Plug control system.

#### **Database development**

In this research, we designed and developed a database system for storing large amounts of sensor data in order to store retrospective statistics for electricity users. The system can store the voltage Amp and Watt variable data of the plug. In addition, retrospective electricity usage statistics also have advantages for further development in other researches. Due to the data of electricity consumption behavior is important for the development of Electrical control system, Power generation system or Smart Grid system to be more efficiency. However, storing large amounts of data and then retrieving such information in less time seems difficult. The development of Database system requires Dig data technology, a large data management technology that contains a large amount of information that ordinary software or hardware is unable to manage or analyze effectively. In this research, MySQL and InfluxDB database are applied. The application of both databases in the work is to bring the advantages of each database to coordinate each other. According to the experiment results to compare the data retrieval of MySQL and InfluxDB by retrieving 1,000 to 10,000 data, it was found that MySQL will spend more time retrieving data if there is a lot of data. Retrieving 1,000 data takes an average of 0.523 ms, while retrieving 10,000 data takes 8.825 ms. As for InfluxDB, regardless of the data amount is retrieved, it will take a similar time, using an average

of 5.746 ms. According to the figures, it can be concluded that MySQL is suitable for retrieving small data, as for InfluxDB is suitable for storing large data. Nevertheless, if the large data has a complex relationship or connection, it may cause InfluxDB to operate with more speed. Therefore, implementing both types of databases to coordinate together will result in the most efficient database system. In this research, MySQL is designed to store data of Settings, Plugs details, User data, User group and other data with complex relationships. The web system will process these information and then bring the results to retrieve the data of electricity usage statistics or other statistics to display on the web. As a result of the development of such database systems, there was no errors found. The system can use the advantages of each database to display the results without errors and still maintain the maximum speed of retrieving the data from both databases. Therefore, it can be concluded that the design and development of the database system is part of the process affecting overall system stability and high speed as well.

Regarding to testing results of DC Smart Plug development, it was found that the design and development of hardware and software are as specified and able to operate perfectly. The test results presented that there was no error in the operation of the entire system. The system can manage with variables affecting the instability of Smart Plug, for instance, System operation accuracy, WIFI signal quality, Communication system and Database system. Such variables affecting the stability of the system have been solved by implementing the capabilities of various technologies to coordinate together. The research on the development of Smart Plug system for DC power therefore considered a good model for further development in other researches. Since this research presented the method to create a sensor to measure the current and voltage of the DC system that can be measured in the range of 0 - 300 Vdc and 0 - 5 Amp which is the measurement range without sensors sold in general. Due to the voltage range of 0 - 300 Vdc is unpopular used, it is mostly used particularly with the research. The development of sensors for measuring DC power consumption during such voltage range is therefore a good model for research in the DC Smart Grid. In addition to the DC Sensor system which considered a prominent point of this research, the development of Cloud and Protocol technology is also an important part that helps the system to be more efficient. In this research, we created a prototype innovation



improving the efficiency of the monitoring system. According to the experiment results of error and transmission time tests, confirming that using programs operating on the Cloud helps reduce the workload of other systems. In addition, a good protocol helps reduce the complexity of data traffic, resulting in less data transmission time. This research is a good example for developing Control system, Communication system and Database for monitoring work.

### **Recommendation**

1. Hardware development must take into account the problems of power supply, since the system power supply is an important variable affecting the accuracy in reading the value of the sensor's data.
2. The development of the Voltage Sensor system using the Voltage Divider principle must be careful in calculating the voltage drop across the two resistors. If the calculation is wrong, it will cause the voltage over 5 VDC resulting in the CMU system to short circuit.
3. The development of program to help record data and calculate the data of electricity consumption rate operating on the Cloud Server in the Java script language will cause errors when receiving data exceeding the specified conditions, for example, wrong data transmission format, incorrect ID information, etc. Program development must take into account such variables together with set a clear conditions for receiving information to avoid errors in calculations
4. The development of the program to help record data automatically is designed to bring information communicating in the MQTT Protocol to record results. At this stage, the system will not be able to input the condition of data recording time, because it may cause the system to calculate every message received, then the system will record all messages received. Such algorithm may cause problems in the future. If people send data using time interval less than 1 ms, it will cause unnecessary use of resources or make a spam to database.
5. The development of data transmission through the MQTT Protocol requires consideration of the security of data communicated with each other. In the process of developing the Smart Plug web control system for DC, the researcher has developed a web-based control using HTML language together with the Java script, a

language operating on the client. Then we applied the Ram memory to let the real time monitor system able to receive or send data at any time. In this algorithm, the user using the program can access into the source code of the system.



## REFERENCES

- Abouzeid, A., Bajda-Pawlikowski, K., Abadi, D., Silberschatz, A., & Rasin, A. (2009). HadoopDB: An architectural hybrid of MapReduce and DBMS technologies for analytical workloads. *Proc. VLDB Endow.*, 2(1), 922-933. doi:10.14778/1687627.1687731
- Ahmed, M. S., Mohamed, A., Homod, R. Z., Shareef, H., Sabry, A. H., & Khalid, K. B. (2015). *Smart plug prototype for monitoring electrical appliances in Home Energy Management System*. Paper presented at the 2015 IEEE Student Conference on Research and Development (SCORED).
- Al-Fuqaha, A., Guizani, M., Mohammadi, M., Aledhari, M., & Ayyash, M. (2015). Internet of things: A survey on enabling technologies, protocols, and applications. *IEEE Communications Surveys & Tutorials*, 17(4), 2347-2376. doi:10.1109/COMST.2015.2444095
- Andrews, F., D. (1974). A robust method for multiple linear regression (Vol. 16). *Technometrics*, 16(4), 523-531.
- Anuradha, M. A., & Massoud, A. (2013). IEEE vision for smart grid controls: 2030 and beyond. *IEEE Vision for Smart Grid Controls: 2030 and Beyond*, 1-168. doi:10.1109/IEEESTD.2013.6577608
- Areed, M. F. (2019). A keyless entry system based on arduino board with wi-fi technology. *measurement*, 139, 34-39. doi:https://doi.org/10.1016/j.measurement.2019.02.028
- Balis, B., Bubak, M., Harezlak, D., Nowakowski, P., Pawlik, M., & Wilk, B. (2017). Towards an operational database for real-time environmental monitoring and early warning systems. *Procedia Computer Science*, 108, 2250-2259. doi:https://doi.org/10.1016/j.procs.2017.05.193
- Bansal, P., & Singh, A. (2016). *Smart metering in smart grid framework: A review*. Paper presented at the 2016 Fourth International Conference on Parallel, Distributed and Grid Computing (PDGC).

- Cai, Y., Sam, C. Y., & Chang, T. (2018). Nexus between clean energy consumption, economic growth and CO<sub>2</sub> emissions. *Journal of Cleaner Production*, 182, 1001-1011. doi:<https://doi.org/10.1016/j.jclepro.2018.02.035>
- Chen, C., & Pomalaza-Raez, C. (2009). *Design and evaluation of a wireless body sensor system for smart home health monitoring*. Paper presented at the GLOBECOM 2009 - 2009 IEEE Global Telecommunications Conference.
- Chen, Y., & Han, D. (2018). Water quality monitoring in smart city: a pilot project. *automation in construction*, 89, 307-316. doi:<https://doi.org/10.1016/j.autcon.2018.02.008>
- Cook, D. J., Youngblood, M., Heierman, E. O., Gopalratnam, K., Rao, S., Litvin, A., & Khawaja, F. (2003). *MavHome: An agent-based smart home*. Paper presented at the Proceedings of the First IEEE International Conference on Pervasive Computing and Communications, 2003. (PerCom 2003).
- Cui, X. (2016). The internet of things. In S. Moran (Ed.), *Ethical ripples of creativity and innovation* (pp. 61-68). London: Palgrave Macmillan UK.
- Daly, C. J., Moore, D. L., Haddad, R. J., Specht, A., & Neal, S. (2018). *PicoGrid smart home energy management system*. Paper presented at the SoutheastCon 2018.
- Deese, A. S., & Daum, J. (2018). Application of zigbee-based internet of things technology to demand response in smart grids. *IFAC-PapersOnLine*, 51(28), 43-48. doi:<https://doi.org/10.1016/j.ifacol.2018.11.675>
- Dezfouli, B., Amirtharaj, I., & Li, C.-C. (2018). EMPIOT: An energy measurement platform for wireless IoT devices. *Journal of Network and Computer Applications*, 121, 135-148. doi:<https://doi.org/10.1016/j.jnca.2018.07.016>
- Ding, F., Song, A., Tong, E., & Li, J. (2016). A smart gateway architecture for improving efficiency of home network applications. *Journal of Sensors*, 2016, 10. doi:10.1155/2016/2197237
- Dorri, A., Kanhere, S. S., Jurdak, R., & Gauravaram, P. (2017). *Blockchain for IoT security and privacy: The case study of a smart home*. Paper presented at the 2017 IEEE International Conference on Pervasive Computing and Communications Workshops (PerCom Workshops).

- Dunfan, Y., Daoli, G., & Wei, W. (2009). *Application of wireless sensor networks in environmental monitoring*. Paper presented at the 2009 2nd International Conference on Power Electronics and Intelligent Transportation System (PEITS).
- Fairley, P. (2012). DC versus AC: The second war of currents has already begun. *IEEE Power and Energy Magazine*, 10(6), 104-103. doi:10.1109/MPE.2012.2212617
- Ferdoush, S., & Li, X. (2014). Wireless sensor network system design using raspberry pi and arduino for environmental monitoring applications. *Procedia Computer Science*, 34, 103-110. doi:https://doi.org/10.1016/j.procs.2014.07.059
- Fernández-Caramés, T. M. (2015). An intelligent power outlet system for the smart home of the internet of things. *International Journal of Distributed Sensor Networks*, 11(11), 214805. doi:10.1155/2015/214805
- Galera, K. M. E., & Llantos, O. E. (2017). Mobile web energy monitoring system using dfrduino uno. *Procedia Computer Science*, 124, 706-713. doi:https://doi.org/10.1016/j.procs.2017.12.208
- Galliana, F., Capra, P. P., Cerri, R., & Lanzillotti, M. (2018). Automated precision DC voltage fixed ratios divider. *Measurement*, 122, 291-296. doi:https://doi.org/10.1016/j.measurement.2018.03.045
- Gungor, V. C., & Korkmaz, M. K. (2012). Wireless link-quality estimation in smart grid environments. *International Journal of Distributed Sensor Networks*, 8(2), 214068. doi:10.1155/2012/214068
- Guo, Z., Zhou, K., Zhang, C., Lu, X., Chen, W., & Yang, S. (2018). Residential electricity consumption behavior: Influencing factors, related theories and intervention strategies. *Renewable and Sustainable Energy Reviews*, 81, 399-412. doi:https://doi.org/10.1016/j.rser.2017.07.046
- Hamdan, O., Shanableh, H., Zaki, I., Al-Ali, A. R., & Shanableh, T. (2019). *IoT-based interactive dual mode smart home automation*. Paper presented at the 2019 IEEE International Conference on Consumer Electronics (ICCE).
- Hammerstrom, D. J. (2007). *AC versus DC distribution systems did we get it right?* Paper presented at the 2007 IEEE Power Engineering Society General Meeting.

- Han, D., & Lim, J. (2010). Smart home energy management system using IEEE 802.15.4 and zigbee. *IEEE Transactions on Consumer Electronics*, 56(3), 1403-1410. doi:10.1109/TCE.2010.5606276
- Han, H., Wang, H., Sun, Y., Yang, J., & Liu, Z. (2017). Distributed control scheme on cost optimisation under communication delays for DC microgrids. *IET Generation, Transmission & Distribution*, 11(17), 4193-4201. Retrieved from <https://digital-library.theiet.org/content/journals/10.1049/iet-gtd.2016.17>
- Hanschke, L., Heitmann, J., & Renner, C. (2016). *Challenges of WiFi-enabled and solar-powered sensors for smart ports*. Paper presented at the Proceedings of the 4th International Workshop on Energy Harvesting and Energy-Neutral Sensing Systems, Stanford, CA, USA.
- Hargreaves, T., Wilson, C., & Hauxwell-Baldwin, R. (2018). Learning to live in a smart home. *Building Research & Information*, 46(1), 127-139. doi:10.1080/09613218.2017.1286882
- Heayyoung, J., Omori, T., & Ohnishi, A. (2019). *Ripple effect analysis method of data flow diagrams in modifying data flow requirements*. Paper presented at the Knowledge-Based Software Engineering: 2018, Cham.
- Huang, P. Y., & Shimizu, T. (2018). *High power/current inductor loss measurement with shunt resistor current-sensing method*. Paper presented at the 2018 International Power Electronics Conference (IPEC-Niigata 2018 -ECCE Asia).
- Hunkeler, U., Truong, H. L., & Stanford-Clark, A. (2008). *MQTT-S — A publish/subscribe protocol for wireless sensor networks*. Paper presented at the 2008 3rd International Conference on Communication Systems Software and Middleware and Workshops (COMSWARE '08).
- Iqbal, R., Lee, J., & Hall, J. (2018). *A cloud middleware enabling natural speech analysis for iot policy enforcement in smart home environments*. Paper presented at the 2018 IEEE International Congress on Internet of Things (ICIOT).

- Jensen, R. H., Strengers, Y., Kjeldskov, J., Nicholls, L., & Skov, M. B. (2018). *Designing the desirable smart home: a study of household; experiences and energy consumption impacts*. Paper presented at the Proceedings of the 2018 CHI Conference on Human Factors in Computing Systems, Montreal QC, Canada.
- Jin, Z., Sulligoi, G., Cuzner, R., Meng, L., Vasquez, J. C., & Guerrero, J. M. (2016). Next-generation shipboard DC power system: Introduction smart grid and dc microgrid technologies into maritime electrical networks. *IEEE Electrification Magazine*, 4(2), 45-57. doi:10.1109/MELE.2016.2544203
- Judewicz, M. G., González, S. A., Echeverría, N. I., Fischer, J. R., & Carrica, D. O. (2016). Generalized predictive current control (GPCC) for grid-tie three-phase inverters. *IEEE Transactions on Industrial Electronics*, 63(7), 4475-4484. doi:10.1109/TIE.2015.2508934
- Jyotheeswara Reddy, K., & Natarajan, S. (2018). Energy sources and multi-input DC-DC converters used in hybrid electric vehicle applications – A review. *International Journal of Hydrogen Energy*, 43(36), 17387-17408. doi:https://doi.org/10.1016/j.ijhydene.2018.07.076
- Kabir, E., Kumar, P., Kumar, S., Adelodun, A. A., & Kim, K.-H. (2018). Solar energy: Potential and future prospects. *Renewable and Sustainable Energy Reviews*, 82, 894-900. doi:https://doi.org/10.1016/j.rser.2017.09.094
- Kon, S., & Yamada, T. (2015). *Effect of current heating on accurate measurements of AC shunt resistors*. Paper presented at the 2015 International Conference on Electronics Packaging and iMAPS All Asia Conference (ICEP-IAAC).
- Kovačević, U. D., Stanković, K. Đ., Kartalović, N. M., & Lončar, B. B. (2018). Design of capacitive voltage divider for measuring ultrafast voltages. *International Journal of Electrical Power & Energy Systems*, 99, 426-433. doi:https://doi.org/10.1016/j.ijepes.2018.01.030
- Kumar, S., Verma, A. R., & Nagesh, C. H. (2019). *GSM-based advanced multi-switching dtmf controller for remotely monitoring of electrical appliances*. Paper presented at the Emerging Research in Electronics, Computer Science and Technology, Singapore.

- Lee, I., & Lee, K. (2015). The Internet of Things (IoT): Applications, investments, and challenges for enterprises. *Business Horizons*, 58(4), 431-440. doi:<https://doi.org/10.1016/j.bushor.2015.03.008>
- Lee, S., Kim, H., Hong, D., & Ju, H. (2013). *Correlation analysis of MQTT loss and delay according to QoS level*. Paper presented at the The International Conference on Information Networking 2013 (ICOIN).
- Leonardi, A., Ziekow, H., Strohbach, M., & Kikiras, P. (2016). Dealing with data quality in smart home environments—lessons learned from a smart grid pilot. *Journal of Sensor and Actuator Networks*, 5(1), 5.
- Li, C., Bosio, F. d., Chen, F., Chaudhary, S. K., Vasquez, J. C., & Guerrero, J. M. (2017). Economic dispatch for operating cost minimization under real-time pricing in droop-controlled dc microgrid. *IEEE Journal of Emerging and Selected Topics in Power Electronics*, 5(1), 587-595. doi:10.1109/JESTPE.2016.2634026
- Li, H., Zhang, H., Peng, D., & Huang, W. (2009). *Design and application of communication gateway based on flexray and CAN*. Paper presented at the 2009 International Conference on Electronic Computer Technology.
- Lin, Y., Huang, C., Chen, L., Sung, G., & Yang, C. (2018). MorSocket: An expandable IoT-based smart socket system. *IEEE Access*, 6, 53123-53132. doi:10.1109/ACCESS.2018.2870281
- Liu, Q., Yang, X., & Deng, L. (2018). An IBeacon-Based location system for smart home control. *sensors*, 18(6). doi:10.3390/s18061897
- Liu, Y., Zeng, X., Zhang, K., & Zou, Y. (2018). *Transforming entity-relationship diagrams to relational schemas using a graph grammar formalism*. Paper presented at the 2018 IEEE International Conference on Progress in Informatics and Computing (PIC).
- Lynggaard, P., & Skouby, K. (2015). Deploying 5G-technologies in smart city and smart home wireless sensor networks with interferences (Vol. 81). *Wireless Personal Communications*, 81(4), 1399-1413.



- Manohar, H. L., & Reuban Gnana Asir, T. (2018). *Data consumption pattern of MQTT protocol for iot applications*. Paper presented at the Smart Secure Systems – IoT and Analytics Perspective, Singapore.
- Marikyan, D., Papagiannidis, S., & Alamanos, E. (2019). A systematic review of the smart home literature: A user perspective. *Technological Forecasting and Social Change*, 138, 139-154. doi:<https://doi.org/10.1016/j.techfore.2018.08.015>
- Matabuena, D., Bellido-Outeirino, F. J., Moreno-Munoz, A., Gil-de-Castro, A., & Flores-Arias, J. M. (2018). *Educational platform for communications using the MQTT protocol*. Paper presented at the 2018 XIII Technologies Applied to Electronics Teaching Conference (TAEF).
- Miller, M. T., Johns, M. B., Sortomme, E., & Venkata, S. S. (2012). *Advanced integration of distributed energy resources*. Paper presented at the 2012 IEEE Power and Energy Society General Meeting.
- Nagar, B. C., & Paul, S. K. (2018). Single OTRA based two quadrant analog voltage divider. *Analog Integrated Circuits and Signal Processing*, 94(1), 161-169. doi:10.1007/s10470-017-1085-1
- Nandipati, S. H., Babu, P. T., Chigurupati, M., & Vaithilingam, C. (2017). Interface protection and energy management system for microgrid using internet of things. *Energy Procedia*, 117, 201-208. doi:<https://doi.org/10.1016/j.egypro.2017.05.123>
- Nasr, E., Kfoury, E., & Khoury, D. (2019). A pervasive IoT scheme to vehicle overspeed detection and reporting using MQTT protocol. In Y. Baghdadi & A. Harfouche (Eds.), *ICT for a better life and a better world: The impact of information and communication technologies on organizations and society* (pp. 19-34). Cham: Springer International Publishing.
- Nguyen, T. D., Tran, V. K., Nguyen, T. D., Le, N. T., & Le, M. H. (2018). *IoT-based smart plug-in device for home energy management system*. Paper presented at the 2018 4th International Conference on Green Technology and Sustainable Development (GTSD).

- Oliveira, J. C. d., Santos, D. H., & Neto, M. P. (2016). *Chatting with Arduino platform through Telegram Bot*. Paper presented at the 2016 IEEE International Symposium on Consumer Electronics (ISCE).
- Pacha, M., Varecha, P., & Sumega, M. (2018). *HW issues of current sensing by DC-link shunt resistor*. Paper presented at the 2018 ELEKTRO.
- Pilloni, V., Floris, A., Meloni, A., & Atzori, L. (2018). Smart home energy management including renewable sources: A QoE-Driven Approach. *IEEE Transactions on Smart Grid*, 9(3), 2006-2018. doi:10.1109/TSG.2016.2605182
- Rahman, M. M., Noor, E. J., Islam, M. O., & Salakin, M. S. (2015). *Arduino and GSM based smart energy meter for advanced metering and billing system*. Paper presented at the 2015 International Conference on Electrical Engineering and Information Communication Technology (ICEEICT).
- Rau, G. H., & Baird, J. R. (2018). Negative-CO<sub>2</sub>-emissions ocean thermal energy conversion. *Renewable and Sustainable Energy Reviews*, 95, 265-272. doi:<https://doi.org/10.1016/j.rser.2018.07.027>
- Raupach, M. R., Marland, G., Ciais, P., Le Quéré, C., Canadell, J. G., Klepper, G., & Field, C. B. (2007). Global and regional drivers of accelerating CO<sub>2</sub> emissions. *Proceedings of the National Academy of Sciences*, 104(24), 10288-10293. doi:10.1073/pnas.0700609104
- Sahu, A., Gupta, S., Singh, V. K., Bhoi, A. K., Garg, A., & Sherpa, K. S. (2018). *Design of permanent magnet synchronous generator for wind energy conversion system*. Paper presented at the Advances in Smart Grid and Renewable Energy, Singapore.
- Salahuddin, M., Alam, K., Ozturk, I., & Sohag, K. (2018). The effects of electricity consumption, economic growth, financial development and foreign direct investment on CO<sub>2</sub> emissions in Kuwait. *Renewable and Sustainable Energy Reviews*, 81, 2002-2010. doi:<https://doi.org/10.1016/j.rser.2017.06.009>
- Santoso, F. K., & Vun, N. C. H. (2015). *Securing IoT for smart home system*. Paper presented at the 2015 International Symposium on Consumer Electronics (ISCE).

- Sharon, Y., Khachatryan, B., & Cheskis, D. (2018). Towards a low current hall effect sensor. *Sensors and Actuators A: Physical*, 279, 278-283. doi:<https://doi.org/10.1016/j.sna.2018.06.027>
- Shin, J., Park, Y., & Lee, D. (2018). Who will be smart home users? An analysis of adoption and diffusion of smart homes. *Technological Forecasting and Social Change*, 134, 246-253. doi:<https://doi.org/10.1016/j.techfore.2018.06.029>
- Shofa, N., Rakhmatsyah, A., & Karimah, S. A. (2017). *Infusion monitoring using WiFi (802.11) through MQTT protocol*. Paper presented at the 2017 5<sup>th</sup> International Conference on Information and Communication Technology (ICoIC7).
- Siebert, T., Troedson, A., & Ebner, S. (2001). *AC to DC power conversion now and in the future*. Paper presented at the Record of Conference Papers. IEEE incorporated Industry Applications Society. Forty-Eighth Annual Conference. 2001 Petroleum and Chemical Industry Technical Conference (Cat. No.01CH37265).
- Singh, S., Jha, R., Ranjan, P., & Tripathy, M. R. (2015). *Software aspects of WSN for monitoring in an Indian greenhouse*. Paper presented at the 2015 International Conference on Computational Intelligence and Communication Networks (CICN).
- Sion, L., Yskout, K., Landuyt, D. V., & Joosen, W. (2018). *Solution-aware data flow diagrams for security threat modeling*. Paper presented at the Proceedings of the 33rd Annual ACM Symposium on Applied Computing, Pau, France.
- Stojkovic, B., & Vukasovic, M. (2006). *A new SCADA system design in the power system of montenegro - ICCP/TASE.2 and Web-based real-time electricity demand metering extensions*. Paper presented at the 2006 IEEE PES Power Systems Conference and Exposition.
- Stonebraker, M., Abadi, D. J., Batkin, A., Chen, X., Cherniack, M., Ferreira, & M., Zdonik, S. (2005). *C-store: a column-oriented DBMS*. Paper presented at the Proceedings of the 31<sup>st</sup> international conference on Very large data bases, Trondheim, Norway.
- Su, M., Liu, Z., Sun, Y., Han, H., & Hou, X. (2018). Stability analysis and stabilization methods of DC microgrid with multiple parallel-connected DC–DC converters

- loaded by CPLs. *IEEE Transactions on Smart Grid*, 9(1), 132-142. doi:10.1109/TSG.2016.2546551
- Su, Y., Fu, G., Wan, B., Zhang, D., & Ma, X. (2019). Failure analysis of hall-effect sensors in brushless DC starter/generator. *Engineering Failure Analysis*, 103, 226-237. doi:https://doi.org/10.1016/j.engfailanal.2019.04.018
- Subramanian, S., Zhang, Y., Vaidyanathan, R., Gunawi, H. S., Arpaci-Dusseau, A. C., Arpaci-Dusseau, R. H., & Naughton, J. F. (2010). *Impact of disk corruption on open-source DBMS*. Paper presented at the 2010 IEEE 26<sup>th</sup> International Conference on Data Engineering (ICDE 2010).
- Šuch, O., Klimo, M., Kemp, N. T., & Škvarek, O. (2018). Passive memristor synaptic circuits with multiple timing dependent plasticity mechanisms. *AEU - International Journal of Electronics and Communications*, 96, 252-259. doi:https://doi.org/10.1016/j.aeue.2018.09.025
- Tao, M., Zuo, J., Liu, Z., Castiglione, A., & Palmieri, F. (2018). Multi-layer cloud architectural model and ontology-based security service framework for IoT-based smart homes. *Future Generation Computer Systems*, 78, 1040-1051. doi:https://doi.org/10.1016/j.future.2016.11.011
- Thaker, T. (2016). *ESP8266 based implementation of wireless sensor network with Linux based web-server*. Paper presented at the 2016 Symposium on Colossal Data Analysis and Networking (CDAN).
- Ulloa, F., García-Santander, L., Carrizo, D., & Hurtado, C. (2018). Towards a home energy management model through a coordinator of smart sockets. *Latvian Journal of Physics and Technical Sciences*, 55(4), 35-43. doi:https://doi.org/10.2478/lpts-2018-0027
- Valtchev, D., & Frankov, I. (2002). Service gateway architecture for a smart home. *IEEE Communications Magazine*, 40(4), 126-132. doi:10.1109/35.995862
- Vanus, J., Kucera, P., Martinek, R., & Koziorek, J. (2014). Development and testing of a visualization application software, implemented with wireless control system in smart home care. *Human-centric Computing and Information Sciences*, 4(1), 18. doi:10.1186/s13673-014-0019-5

- Viani, F., Robol, F., Polo, A., Rocca, P., Oliveri, G., & Massa, A. (2013). Wireless architectures for heterogeneous sensing in smart home applications: Concepts and Real Implementation. *Proceedings of the IEEE*, 101(11), 2381-2396. doi:10.1109/JPROC.2013.2266858
- Villa, F., Moreno, F., & Guzmán, J. (2018). *An analysis of a methodology that transforms the entity-relationship model into a conceptual model for a graph database*. Paper presented at the Emerging Technologies in Computing, Cham.
- Vujović, V., Maksimović, M., Perišić, B., & Milošević, G. (2015). *A proposition of low cost sensor web implementation based on GSM/GPRS services*. Paper presented at the 2015 IEEE 1<sup>st</sup> International Workshop on Consumer Electronics (CE WS).
- Wang, S., Li, G., & Fang, C. (2018). Urbanization, economic growth, energy consumption, and CO2 emissions: Empirical evidence from countries with different income levels. *Renewable and Sustainable Energy Reviews*, 81, 2144-2159. doi:https://doi.org/10.1016/j.rser.2017.06.025
- Wang, S., Lin, S., & Li, J. (2018). Exploring the effects of non-cognitive and emotional factors on household electricity saving behavior. *Energy Policy*, 115, 171-180. doi:https://doi.org/10.1016/j.enpol.2018.01.012
- Wu, C., Liao, C., & Fu, L. (2007). Service-oriented smart-home architecture based on OSGi and mobile-agent technology. *IEEE Transactions on Systems, Man, and Cybernetics, Part C (Applications and Reviews)*, 37(2), 193-205. doi:10.1109/TSMCC.2006.886997
- Wu, Y., Wang, Q., & Wang, J. (2019). *An interactive appliances' intelligent control method based on time-sharing electricity price*. Paper presented at the Recent Advances in Intelligent Information Hiding and Multimedia Signal Processing, Cham.
- Zhang, H., Liu, W., Xiong, H., & Dong, X. (2018). Analyzing data flow diagrams by combination of formal methods and visualization techniques. *Journal of Visual Languages & Computing*, 48, 41-51. doi:https://doi.org/10.1016/j.jvlc.2018.08.001

- Zhang, J., Zhou, Z., Li, S., Gan, L., Zhang, X., Qi, L., & Ou, W. (2018). Hybrid computation offloading for smart home automation in mobile cloud computing. *Personal Ubiquitous Comput.*, 22(1), 121-134. doi:10.1007/s00779-017-1095
- Zhao, J., & Gao, Y. (2018). Electrostatic comb-driven actuator for MEMS relay/switch. In Q.-A. Huang (Ed.), *Micro electro mechanical systems* (pp. 907-927). Singapore: Springer Singapore.
- Zhenghua, X., Guolong, C., Li, H., Song, Q., Hu, L., Lei, C., & Yexiang, X. (2014). *The smart home system based on the IAP15F2K61S2 and GSM* (Vol. 7). International Journal on Smart Sensing & Intelligent Systems.



# CURRICULUM VITAE

**Name** Mr. Narakorn Songkittirote

**Address** 202 Changpuak Rd. Muang, Chiang Mai, 50300 Thailand

**Education**

2011-2015 Bachelor's degree in Computer Engineering Faculty of Industrial Technology, Uttaradit Rajabhat University  
Uttaradit, Thailand

**Work Experience**

2011- Current Research Assistant, Asian Development College for Community Economy and Technology (adiCET)  
Chiang Mai Rajabhat University, Chiang Mai,  
Thailand



**DEVELOPMENT OF DC SMART PLUG CONTROL SYSTEM**

การพัฒนาระบบควบคุมปลั๊กอัจฉริยะสำหรับไฟฟ้ากระแสตรง

The seal of Chiang Mai Rajabhat University is a large, faint watermark in the background. It is circular and contains a central emblem featuring a stupa with flames, a caduceus, and a sunburst. The Thai text 'มหาวิทยาลัยราชภัฏเชียงใหม่' is written along the top inner edge, and 'CHIANG MAI RAJABHAT UNIVERSITY' is written along the bottom inner edge.

**NARAKORN SONGKITIROTE**

**A THESIS SUBMITTED IN PARTIAL FULFILLMENT  
OF THE REQUIREMENTS FOR  
THE MASTER OF SCIENCE PROGRAM IN  
COMMUNITY ENERGY AND ENVIRONMENT  
GRADUATE SCHOOL  
CHIANG MAI RAJABHAT UNIVERSITY**

**2019**



